

NO	DESCRIPTION	MAT'L	Q'TY	WT(kg)	REMARKS

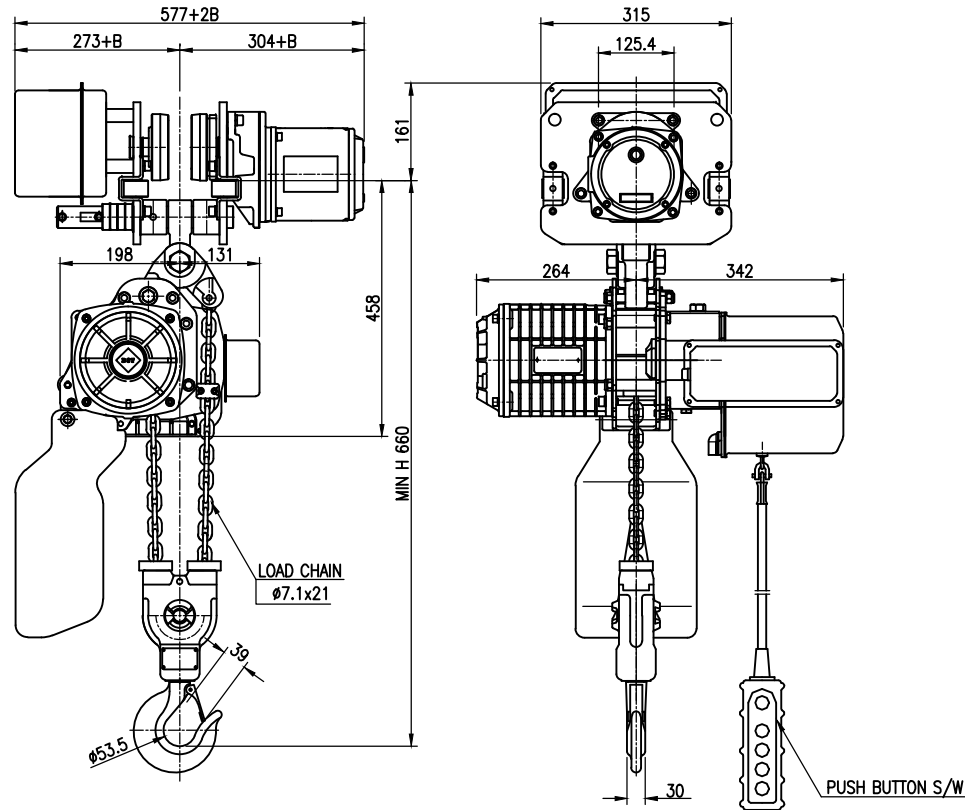

SPECIFICATION		
HOISTING LOAD	2	TON
TESTING LOAD	2.5	TON
LIFTING HEIGHT	4	M
HOISTING	SPEED	1.3-4.1 M/MIN
	MOTOR	1.8 KW x 4P x 1 SET
TRAVERSING	SPEED	5.2-15.2 M/MIN
	MOTOR	0.4 KW x 6P x 1 SET
POWER SUPPLY	AC 220, 380, 460V x 3ø x 50/60 Hz	
OPERATING METHOD	P.B type ON . FL	
WEIGHT	122 KG	
I-BEAM SIZE	100-150	

\* B CALCULATION  $B=1/2 \times (\text{I BEAM WIDTH})$

\* ROLLER DIA :  $\phi 110$

\* LIMIT SWITCH : OPTION

TITLE EDSTM-2W CHAIN HOIST				PROJECTION	
WORK NO		WORK NAME			
				SCALE	Q'TY
				1/1	1
DRAWN	CHECKED	REVIEWED	APPROVED	DRAWING NO	
YOO.M.R	-	LEE. H.J	Y.K	EDSTM2W01	
2013.08.29	-	2013.08.29	2013.08.29		

REV.NO	DATE	REVISION DESCRIPTION	DRAWN	CHECKED	APPROVED

**DAESAN INoTEC INC**