

NO	DESCRIPTION	MAT'L	Q'TY	WT(kg)	REMARKS

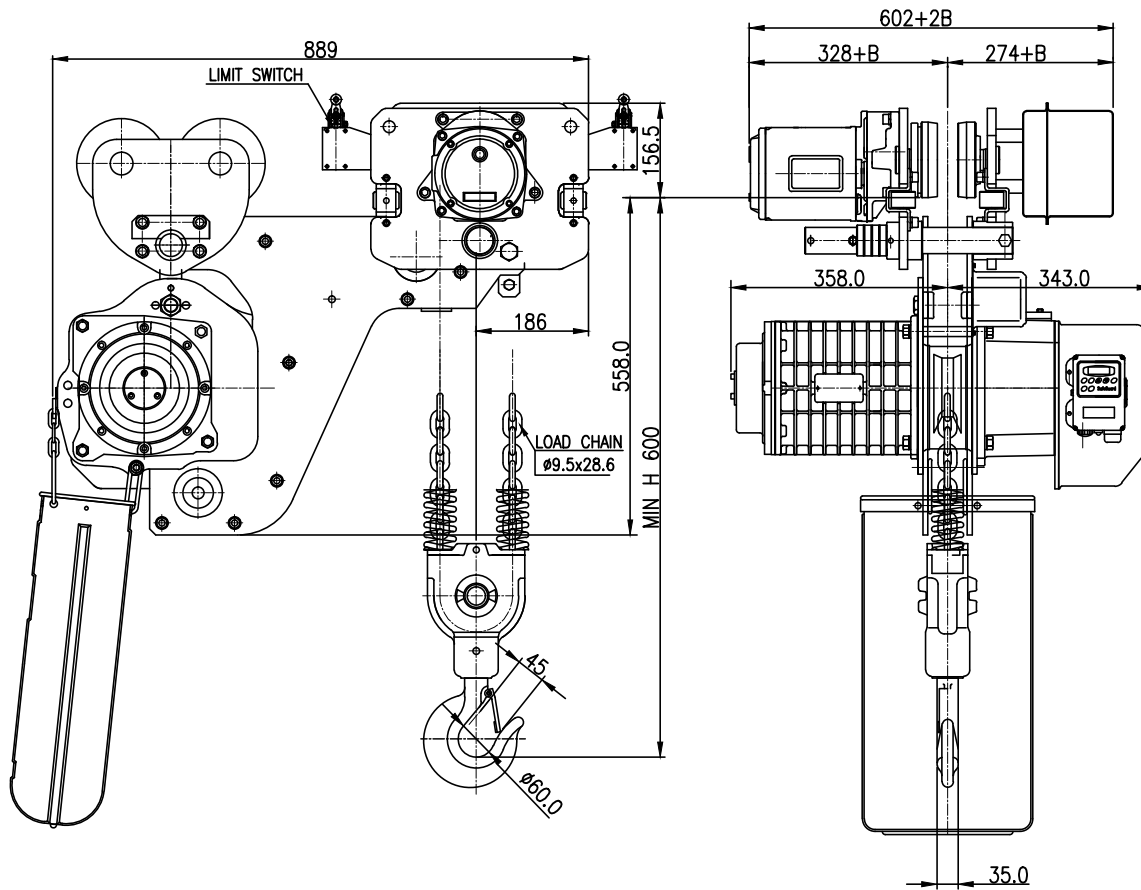

SPECIFICATION		
HOISTING LOAD	3	TON
TESTING LOAD	3.75	TON
LIFTING HEIGHT	5	M
HOISTING	SPEED	1.5~4.6 M/MIN
	MOTOR	3.5 KW x 1 SET
TRAVERSING	SPEED	5.2~15.2 M/MIN
	MOTOR	0.75 KW x 1 SET
POWER SUPPLY	AC 380 x 3ø x 60 Hz	
OPERATING METHOD	P.B type ON . FL	
WEIGHT	281 KG	
I-BEAM SIZE	100-150 MM	

NOTE

- * B는 BEAM 변동치수 치수임.
- * ROLLER DIA : ø125
- * LIMIT SWITCH : OPTION
- * 본 도면은 I-BEAM 100MM 기준임

TITLE EDSHM-3W CHAIN HOIST				PROJECTION	
WORK NO		WORK NAME			
				SCALE	Q'TY
				1/1	1
DRAWN	CHECKED	REVIEWED	APPROVED	DRAWING NO	
H.J	-	LEE	Y. K	EDSH03020	
2020.09.15	-	2020.09.15	2020.09.15		

도면에 지시되지 않은 일반공차						
가공법	치수	3-6	6-30	30-120	120-315	315-1000
선	삭					
구멍간	거리	±0.1	±0.2	±0.3	±0.5	±0.8

REV.NO	DATE	REVISION DESCRIPTION	DRAWN	CHECKED	APPROVED

DAESAN INoTEC INC