

NO	DESCRIPTION	MAT'L	Q'TY	WT(kg)	REMARKS

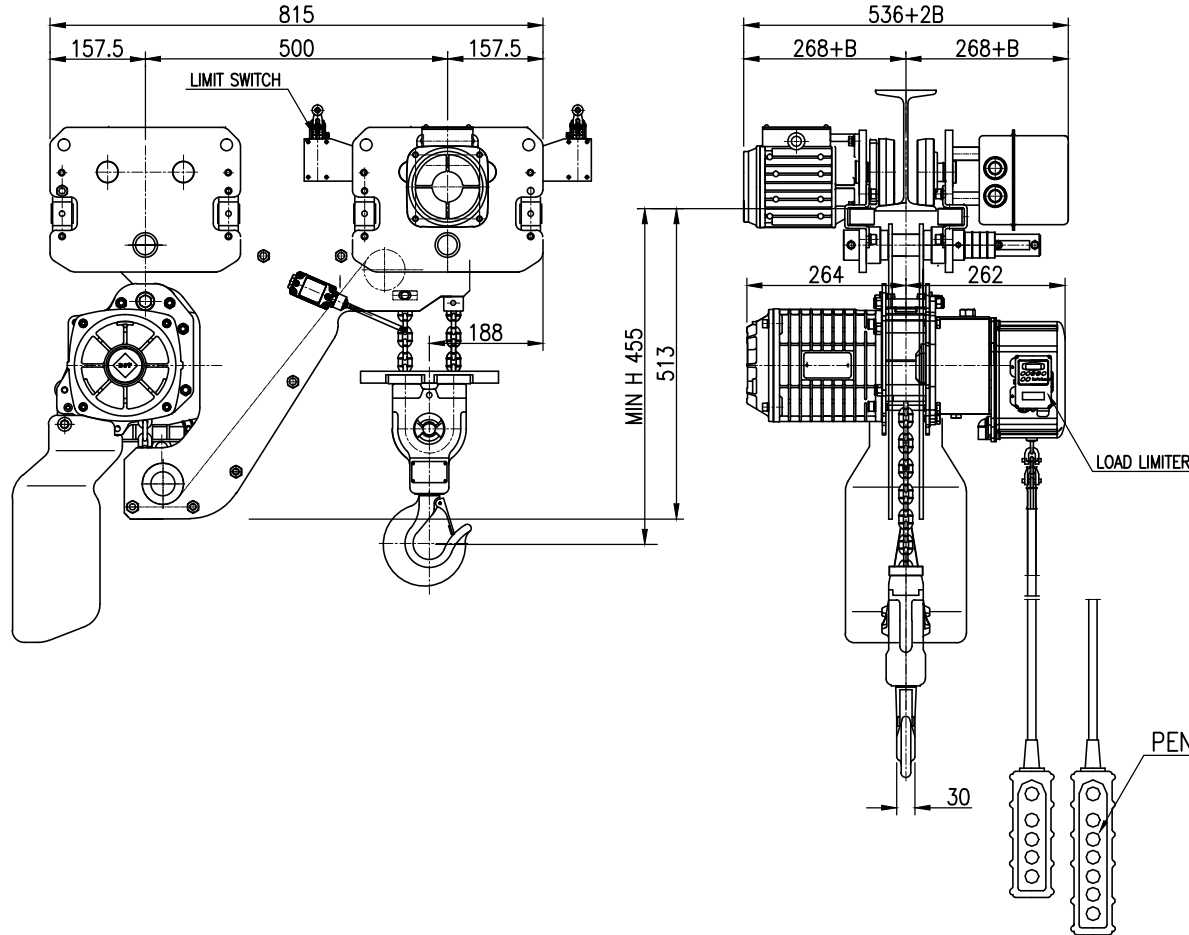

SPECIFICATION		
HOISTING LOAD	2	TON
TESTING LOAD	2.5	TON
LIFTING HEIGHT	4	M
HOISTING	SPEED	4.1 M/MIN
	MOTOR	1.8 KW x 4P x1 SET
TRAVERSING	SPEED	15 /21 M/MIN
	MOTOR	0.4 KW x 6/4P x 1 SET
POWER SUPPLY	AC 220/380, 440V 460,480V x3φ 60HZ	
OPERATING METHOD	P.B type ON . FL	
WEIGHT	152 KG	
I-BEAM SIZE	100-150	

NOTE

- * B는 BEAM 변동치수 임
- * ROLLER DIA : $\varnothing 95$
- * LIMIT SWITCH : OPTION
- * 본 도면은 I-BEAM 100MM 기준임.
- * ADJUSTING COLLAR 내측 1/1 외측 4EA.

TITLE DSTHM-2W CHAIN HOIST				PROJECTION	
WORK NO		WORK NAME			
				SCALE	Q'TY
				1/1	1
DRAWN	CHECKED	REVIEWED	APPROVED	DRAWING NO	
H.J	-	LEE	Y.K	DSTHM2W	
2022.01.25	-	2022.01.25	2022.01.25		
DAESAN INoTEC INC					

REV.NO	DATE	REVISION DESCRIPTION	DRAWN	CHECKED	APPROVED