

NO	DESCRIPTION	MAT'L	Q'TY	WT(kg)	REMARKS

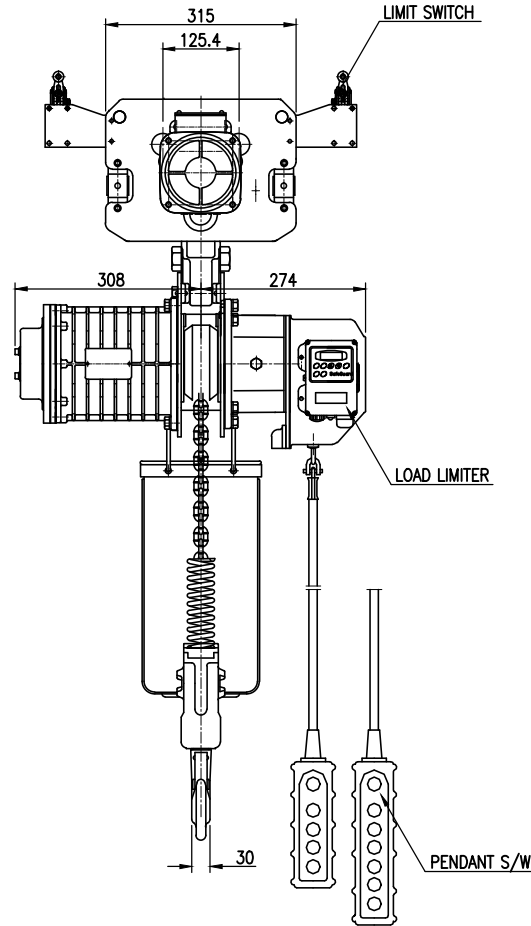
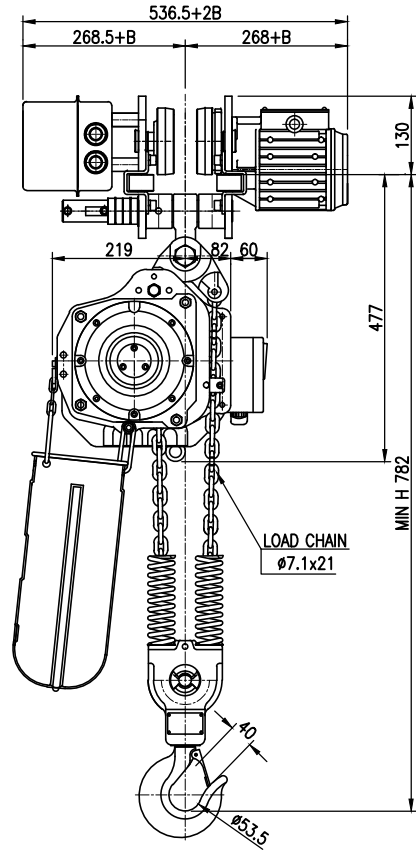

SPECIFICATION			
HOISTING LOAD	1.9	TON	
TESTING LOAD	2.375	TON	
LIFTING HEIGHT	4	M	
HOISTING	SPEED	50/60Hz	3.4/4.1 M/MIN
	MOTOR	1.8 KW x 4P x 1 SET	
TRAVERSING	SPEED	12/15	M/MIN
	MOTOR	0.4 KW x 6P x 1 SET	
POWER SUPPLY	AC220, 380, 440 x 3Ø x 50/60 Hz		
OPERATING METHOD	P.B type ON . FL		
WEIGHT	128 KG		
I-BEAM SIZE	100-150		

- * β는 BEAM폭 치수임.
- * ROLLER DIA : Ø110
- * LIMIT SWITCH : OPTION
- * 본 도면은 I-BEAM 100MM 기준임.

TITLE DSM-1.9W CHAIN HOIST				PROJECTION	
WORK NO		WORK NAME			
				SCALE	Q'TY
				1/1	1
DRAWN	CHECKED	REVIEWED	APPROVED	CODE NO	
H.J	-	LEE	Y.K	DSM19W001	
2021.02.24	-	2021.02.24	2021.02.24		
DAESAN InoTEC INC					

REV.NO	DATE	REVISION DESCRIPTION	DRAWN	CHECKED	APPROVED