

NO	DESCRIPTION	MAT'L	Q'TY	WT(kg)	REMARKS

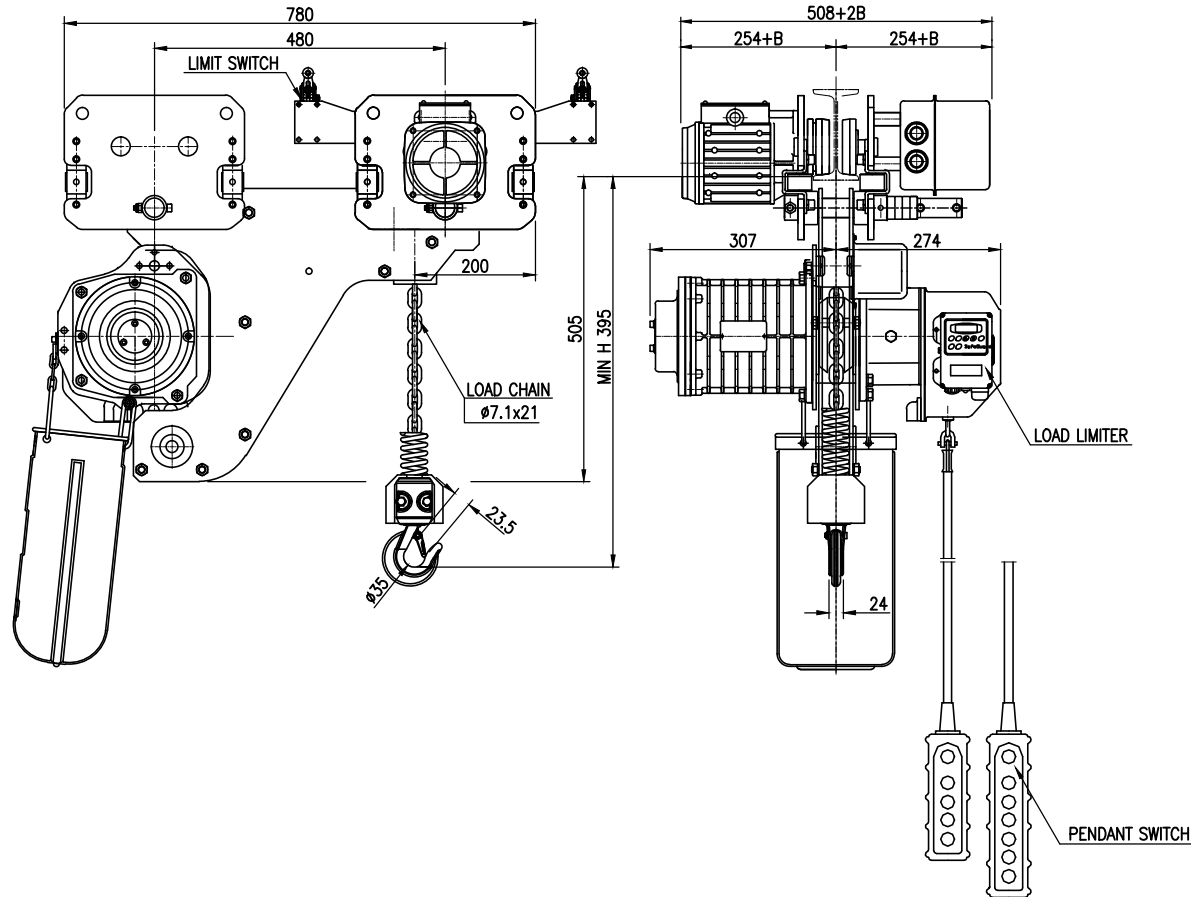

SPECIFICATION

HOISTING LOAD	1	TON
TESTING LOAD	1.25	TON
LIFTING HEIGHT	4	M
HOISTING	SPEED	8.2 M/MIN
	MOTOR	1.8 KW x 4P x 1 SET
TRAVERSING	SPEED	15 M/MIN
	MOTOR	0.4 KW x 6P x 1 SET
POWER SUPPLY	AC 220, 380, 440, 480V x 3ø x 60 Hz	
OPERATING METHOD	P.B type ON . FL	
WEIGHT	146 KG	
I-BEAM SIZE	75-125	

NOTE

- * B 는 BEAM 변동치수 치수임
- * ROLLER DIA : ø95
- * LIMIT SWITCH : OPTION
- * 본 도면은 I-BEAM 75MM 기준임.

TITLE				PROJECTION	
DSHM-1S CHAIN HOIST					
WORK NO		WORK NAME		SCALE	Q'TY
		산형 TROLLEY		1/1	1
DRAWN	CHECKED	REVIEWED	APPROVED	DRAWING NO	
H.J	-	LEE	Y.K	DSHM01S002	
2022.11.30	-	2022.11.30	2022.11.30		

REV.NO	DATE	REVISION DESCRIPTION	DRAWN	CHECKED	APPROVED

DAESAN INoTEC INC