

NO	DESCRIPTION	MAT'L	Q'TY	WT(kg)	REMARKS

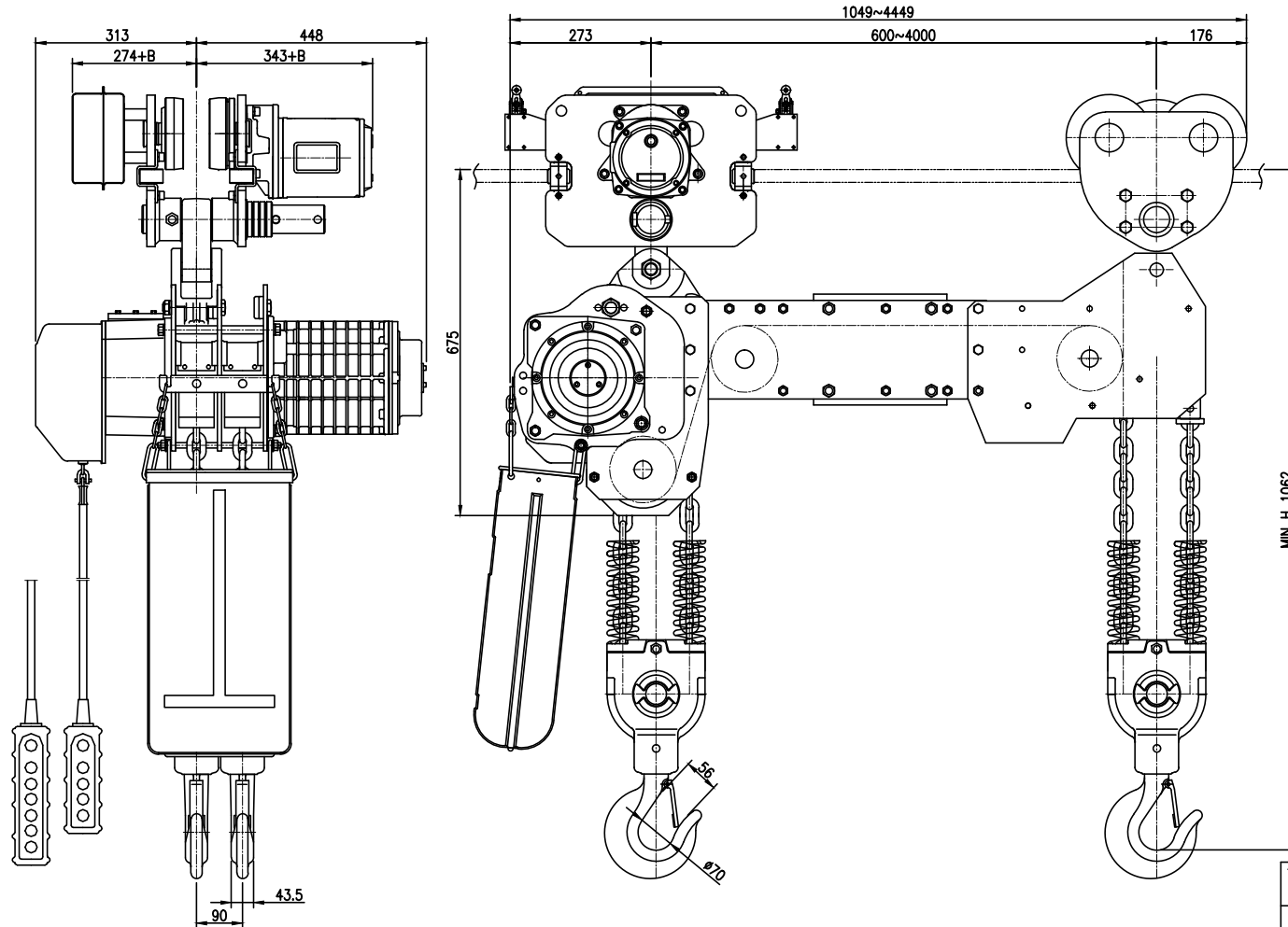

SPECIFICATION		
HOISTING LOAD	5	TON
TESTING LOAD	6.25	TON
LIFTING HEIGHT	5	M
HOISTING	SPEED	2.75/3.25 M/MIN
	MOTOR	3.5KW x 4P x 1 SET
TRAVERSING	SPEED	14/20M/MIN
	MOTOR	0.75 KW x 6/4P x 1 SET
POWER SUPPLY	AC 220,380,440,480 x 3φ x 50/60 Hz	
OPERATING METHOD	P.B type ON . FL	
I-BEAM SIZE	125-175 MM	

NOTE

- \* B는 BEAM 변동값임
- \* ROLLER DIA :  $\phi 140$
- \* LIMIT SWITCH : OPTION
- \* 본 도면은 1-BEAM 125MM 기준임.

TITLE DSDHM-5W CHAIN HOIST				PROJECTION	
WORK NO		WORK NAME			
				SCALE	Q'TY
				1/1	1
DRAWN	CHECKED	REVIEWED	APPROVED	DRAWING NO	
H.J	-	LEE	Y. K	DSDHM05W01	
2020.09.15	-	2020.09.15	2020.09.15		

도면에 지시되지 않은 일반공차					
치수	3-6	6-30	30-120	120-315	315-1000
가공별					
선					
구멍간 거리	±0.1	±0.2	±0.3	±0.5	±0.8

REV.NO	DATE	REVISION DESCRIPTION	DRAWN	CHECKED	APPROVED

**DAESAN INoTEC INC**