

NO	DESCRIPTION	MAT'L	Q'TY	WT(kg)	REMARKS
001	LOAD CHAIN(ELECTROLESS NI PLATING)	MN-B(steel)	5M		
002	HAND CHAIN	SUS304	4M		
003	HOOK	HBsC4	1		
004	LOAD SHEAVE(ELECTROLESS NI PLATING)	FCD45	1		
005	CHAIN WHEEL (ELECTROLESS NI PLATING)	FCD45	1		
006	HOOK COVER (ELECTROLESS NI PLATING)	ZG 25	2		

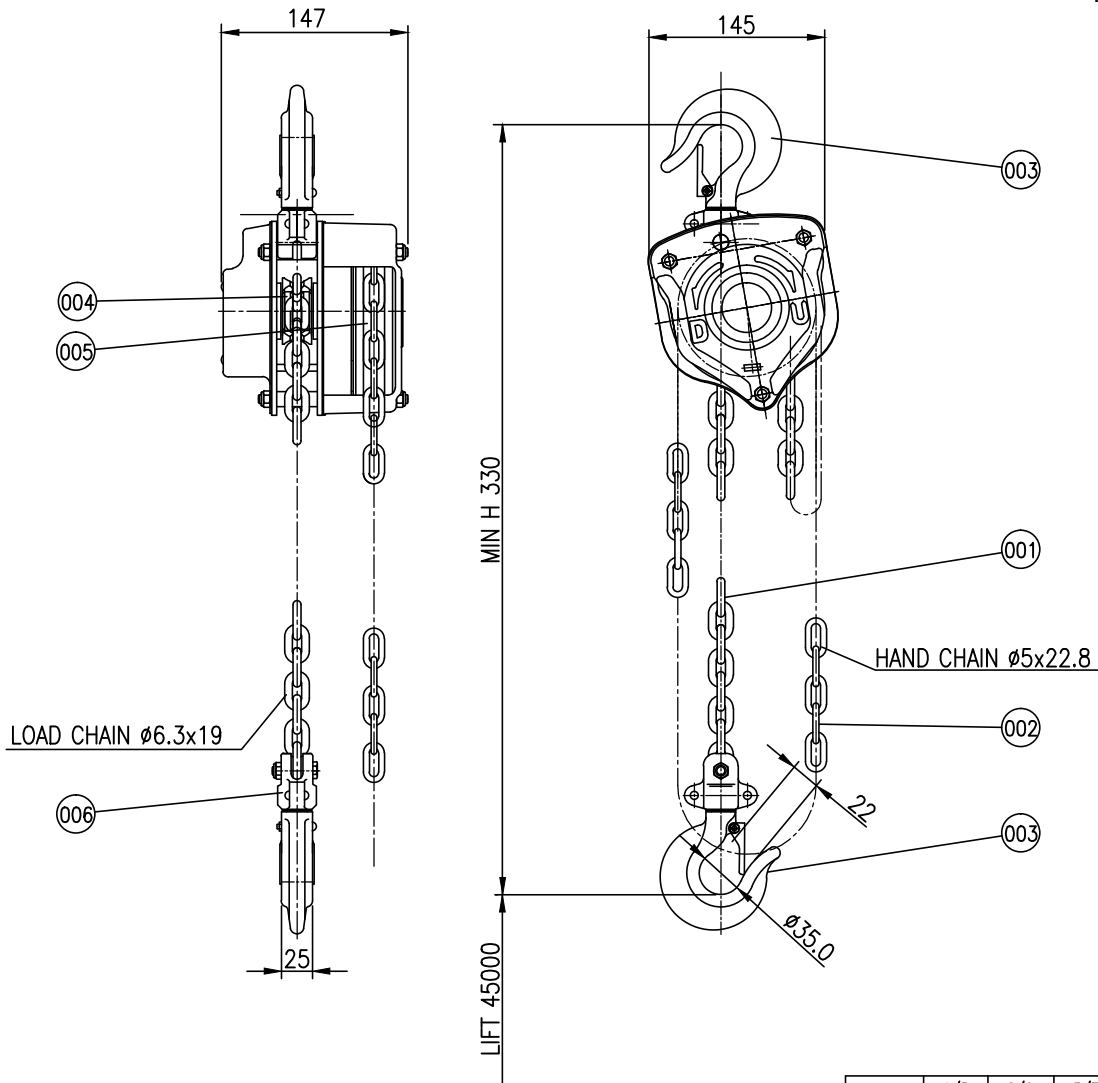

SPECIFICATION	
HOISTING LOAD	1 TON
TESTING LOAD	1.25 TON
LIFTING HEIGHT	2.5 M
HOISTING	MANUAL
WEIGHT	12 kg
LOAD CHAIN	$\phi 6.3 \times 19$

TITLE EXDSN-1TON CHAIN BLOCK				PROJECTION	
WORK NO		WORK NAME			
				SCALE	Q'TY
				1/2	1
DRAWN	CHECKED	REVIEWED	APPROVED	DRAWING NO	
YOO.M.R		LEE. H.J	Y.K	EDSN010001	
2013.07.23		2013.07.23	2013.07.23		

	1/5	2/6	3/7	4/8	
	3-6	6-30	30-120	120-315	315-1000
	±0.1	±0.2	±0.3	±0.5	±0.8

REV.NO	DATE	REVISION DESCRIPTION	DRAWN	CHECKED	APPROVED

DAESAN INoTEC INC