



제 2012 - 114908-1 호

안 전 인 증 서

(사업장명) (주)대산이노텍
(소 재 지) (314-821) 충남 공주시 정안면 사현리 523

위 사업장에서 제조하는 아래의 품목이 산업안전보건법 제34조 및 같은 법 시행규칙 제58조의4제4항에 따른 안전인증 심사 결과 안전·보건기준에 적합하므로 안전인증표시의 사용을 인증합니다.

_____	품	목	_____
	호이스트		
_____	형식,모델(용량,등급)/인증번호		_____
	EDSM-2S (2Ton) /09-AQ2AC-1119		
_____	인	증	기
	노동부 고시 제2010 - 12호 (위험기계,기구 의무안전인증 고시)		준
_____	인	증	조
	조건		_____

2012년 05월 02일

한국산업안전보건공단이사장



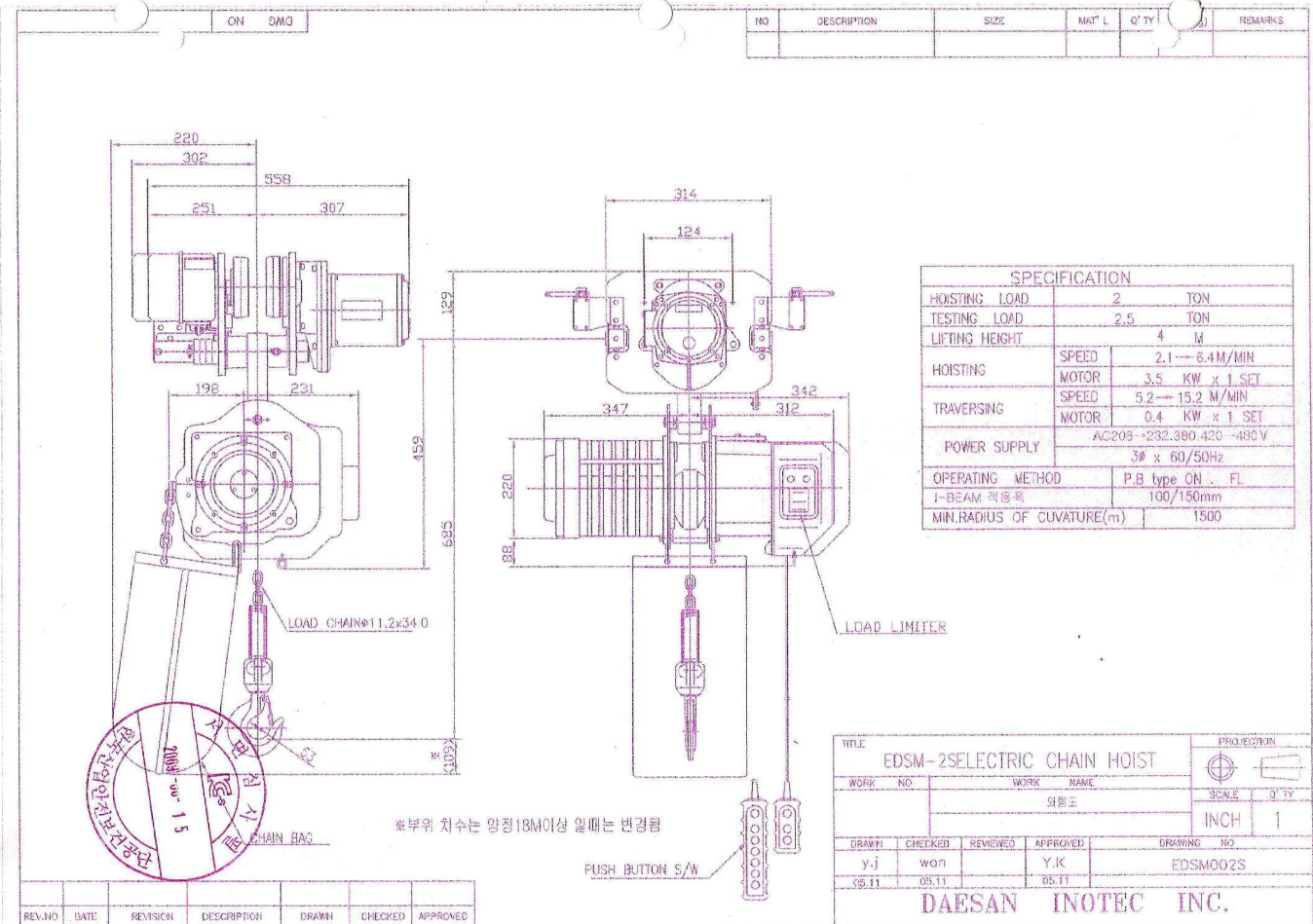

SPECIFICATION	
HOISTING LOAD	2 TON
TESTING LOAD	2.5 TON
LIFTING HEIGHT	4 M
HOISTING	SPEED 2.1---6.4M/MIN MOTOR 3.5 KW x 1 SET
TRAVERSING	SPEED 5.2---15.2 M/MIN MOTOR 0.4 KW x 1 SET
POWER SUPPLY	AC208---232.380.420---480V 3Ø x 60/50Hz
OPERATING METHOD	P.B type ON . FL
I-BEAM 规格	100/150mm
MIN.RADIUS OF CURVATURE(m)	1500

TITLE					PROJECTION	
EDSM-2ELECTRIC CHAIN HOIST						
WORK NO.	WORK NAME				SCALE	Q'TY
	호명도				INCH	1
DRAWN	CHECKED	REVIEWED	APPROVED	DRAWING NO.		
y-j	won		Y.K	EDSM002S		
05.11	05.11		05.11			

DAESAN INOTEC INC.

REV.	NO	DATE	REVISION	DESCRIPTION	DRAWN	CHECKED	APPROVED

EDSM-2S 001.jpg

2 STEP INVERTER CIRCUIT DIAGRAM

MODEL : EDSM-2S,3W,5W(380,440V,3 ϕ ,60HZ)

NO	Commodity	Capacity	Q'TY	Model No.	Maker
----	-----------	----------	------	-----------	-------

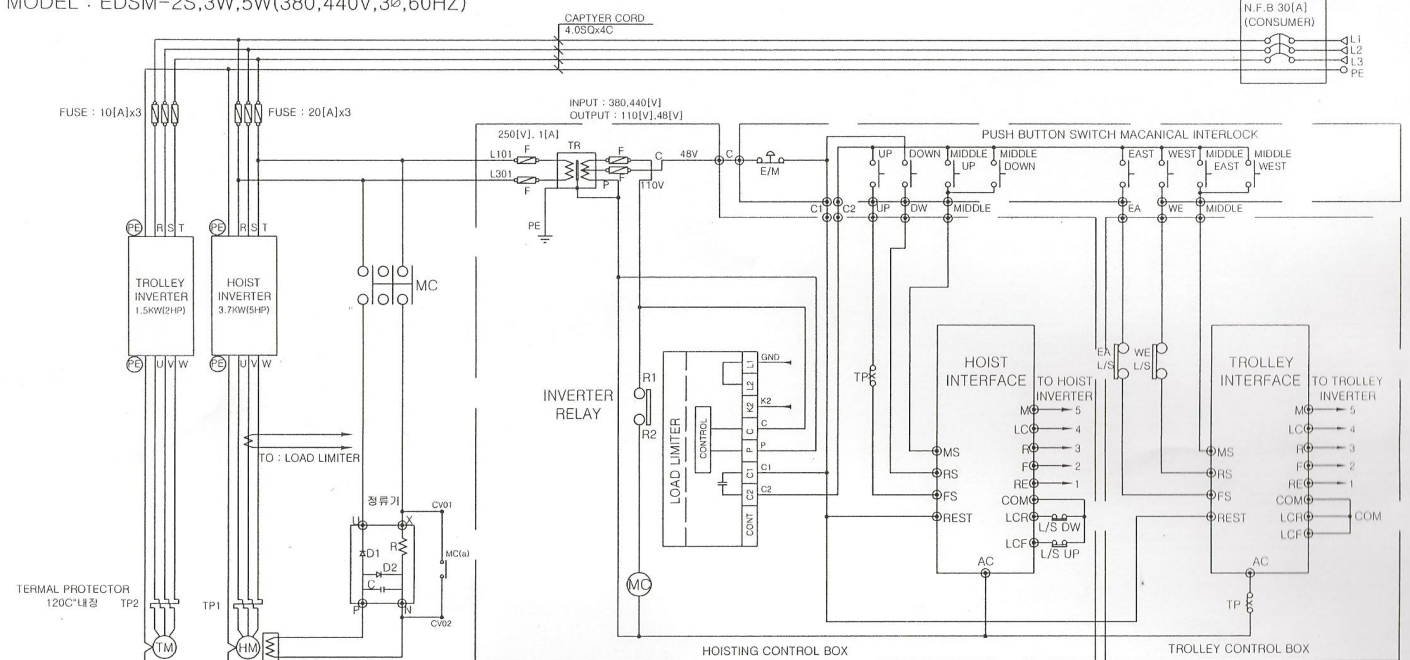

- NOTE**
1. POWER CONNECTION WIRE : 2.5SQ (BLACK)
 2. CONTROL CONNECTION WIRE : 1.5SQ (RED)
 3. 제어전압 : AC 110V
 4. 조작전압 : AC 48V
 5. 휴즈용량 : $\frac{P(W)}{\sqrt{3} \cdot E \cdot \cos\phi}$ X300%이하로 한다.



TITLE 2 STEP INVERTER CIRCUIT				PROJECTION
WORD NO	WORK NAME		SCALE	Q'TY
	EDSM-2S,3W,5W			
	380,440[V]			
DRAWN	CHECKED	REVIEWED	APPROVED	DRAWING NO
Y.J	Y.C		Y.K	EDSM09008
09.05	09.05		09.05	
InoTEC IND. CO., L.TD.				

1	2	3	4	5	6	7	8		
				NO	Commodity	Capacity	Q'TY	Model No.	Maker
ELECTRIC ELEMENTARY DIAGRAM SYBOL LIST									
항목	기 호	약 호	명 칭	항목	기 호	약 호	명 칭		
1	—		WIRE	22		M302	WEST MAGNET CONTACT 주점점		
2			WIRE CONNECTED	23		M101	UP MAGNET CONTACT 보조점점 a점점		
3			TERMINAL	24		M102	DOWN MAGNET CONTACT 보조점점 a점점		
4			접지	25		M101	UP MAGNET CONTACT 보조점점 b점점		
5			전원입력	26		M102	DOWN MAGNET CONTACT 보조점점 b점점		
6			M.C.C.B	27		M301	EAST MAGNET CONTACT 보조점점 b점점		
7			FUSE	28		M302	WEST MAGNET CONTACT 보조점점 b점점		
8			비상스위치	29		UPPER L/S	UP LIMIT SWITCH b점점		
9			PUSH BUTTON SWITCH a점점	30		LOWER L/S	DOWN LIMIT SWITCH b점점		
10			TRANSFORMER	31		EAST L/S	동행 LIMIT SWITCH b점점		
11			정류기	32		WEST L/S	서행 LIMIT SWITCH b점점		
12			CURRENT TRANSFORMER	33		TP1	권상 MOTOR TERMAL PROTECTOR b점점		
13			권상용 MOTOR	34		TP2	동행 MOTOR TERMAL PROTECTOR b점점		
14			동행 MOTOR	35		TP1	권상 MOTOR TERMAL PROTECTOR		
15		M101	UP MAGNET CONTACTOR	36		TP2	동행 MOTOR TERMAL PROTECTOR		
16		M102	DOWN MAGNET CONTACTOR	37		SOL	SOLENOID TYPE DC MAGNET BRAKE COIL		
17		M301	EAST MAGNET CONTACTOR						
18		M302	WEST MAGNET CONTACTOR						
19		M101	UP MAGNET CONTACT 주점점						
20		M102	DOWN MAGNET CONTACT 주점점						
21		M301	EAST MAGNET CONTACT 주점점						



TITLE				ELECTRIC ELEMENTARY DIAGRAM SYMBL LIST		PROJECTION	
WORD NO		WORK NAME				SCALE Q'TY	
		EDSA,EDSM-1S,2S,3W,5W					
DRAWN	CHECKED	REVIEWED	APPROVED	DRAWING NO			
Y.J	Y.C		Y.K	DSE06002			
09.05	09.05		09.05				
INoTEC IND. CO., LTD.							

REV.NO	DATE	REVISION DESCRIPTION	DRAWN	CHECKED	APPROVED
1					

NO	Commodity	Capacity	Q'TY	Model No.	Maker	
INTERLOCK LIST						
순번	기호/약어	명 칭	역 할	차 단 범 위	차 단 방 법	비 고
1	E/M	비상정지 스위치	비상시 전원차단	전동기 및 제어회로의 전원차단	마크네트 스위치 주점접 OPEN	
2	L/S UP	UP 리미트 스위치	한계치 이상 상승시 전동기 전원차단	전동기 전원차단	마크네트 스위치 주점접 OPEN	
3	L/S DOWN	DOWN 리미트 스위치	한계치 이상 하강시 전동기 전원차단	전동기 전원차단	마크네트 스위치 주점접 OPEN	
4	L/S EAST	RIGHT 리미트 스위치	한계치 이상 RIGHT 이동시 전동기 전원차단	전동기 전원차단	마크네트 스위치 주점접 OPEN	OPTION
5	L/S WEST	LEFT 리미트 스위치	한계치 이상 LEFT 이동시 전동기 전원차단	전동기 전원차단	마크네트 스위치 주점접 OPEN	OPTION
6	M101	UP M/C 보조점접 b점접	UP 동작시 DOWN 동작 금지	UP/DOWN 동시투입 금지	M/C 보조점접 b 점접 OPEN	
7	M102	DOWN M/C 보조점접 b점접	DOWN 동작시 UP 동작 금지	UP/DOWN 동시투입 금지	M/C 보조점접 b 점접 OPEN	
8	M301	EAST M/C 보조점접 b점접	RIGHT 동작시 LEFT 동작 금지	UP/DOWN 동시투입 금지	M/C 보조점접 b 점접 OPEN	
9	M302	WEST M/C 보조점접 b점접	LEFT 동작시 RIGHT 동작 금지	UP/DOWN 동시투입 금지	M/C 보조점접 b 점접 OPEN	
10	역상방지	역상방지	UP/DOWN 역상결선시 CONTROL회로 전원차단 UP/DOWN 동작 금지	UP/DOWN 동시투입 금지	내부 RELAY 보조점접 b 점접 OPEN	
11	LOAD LIMITER	LOAD LIMITER	과부하 운전시 UP CONTROL 회로 전원차단 UP 동작 금지	과부하 운전 금지	UP CONTROL회로 전원차단	
12	TP	TERMINAL RELAY	한계치 이상 온도 상승시 전동기 전원차단	전동기 전원차단	TP 내부점접 OPEN	전동기 내장



TITLE		interlock 목록표		PROJECTION	
WORD NO		WORK NAME		SCALE Q'TY	
		EDSA.EDSM - 1S.2S.3W.5W 220[V].360[V].440[V]			
DRAWN	CHECKED	REVIEWED	APPROVED	DRAWING NO	
Y.J	Y.C		Y.K	DS06E014	
09.05	09.05		09.05		
INoTEC IND. CO., LTD.					

REV.NO	DATE	REVISION DESCRIPTION	DRAWN	CHECKED	APPROVED

EDSM-132.JPG

FEC CHAIN CORPORATION	337 KANAORI-CHO, HAMAMATSU CITY, SHIZUOKA PRE.,435-0026 JAPAN
TEL:+81-53-425-4116, 2162	FAX:+81-53-425-5122

TEST CERTIFICATE

Distributor: Coustomer:	code #: 1080	distributor's name: ASAO & CO., LTD	coustomer's name:
Article name: (Application)	Load chain for electric chain hoist		
Spec. standard	<input type="checkbox"/> DIN EN 818-7:2002, <input type="checkbox"/> JIS B 8812:1999 <input type="checkbox"/> ISO 3077, <input checked="" type="checkbox"/> FEC		
Material spec.:	SAE15B24(Mn-B steel)		
Finish:	<input checked="" type="checkbox"/> temper-colored, <input type="checkbox"/> zinc-plated, <input type="checkbox"/> coated() <input type="checkbox"/> zinc-phosphated, <input type="checkbox"/> manganese-phosphated <input checked="" type="checkbox"/> oiled, <input type="checkbox"/> o-oiled		
Stamping:	<input type="checkbox"/> FEC standard, <input checked="" type="checkbox"/> coustomer's request → DS, JAPAN, (Lot #), FEC#		
Product code#: description: quality type	FCD11234 φ 11.2*P34 G80/ type-DAT		

			Result
Dimention:			
Nominal diameter(dn)	[mm]	11.2 +0.3/-0.3	Good
Internal width,min.:	[mm]	14.0	Good
external width, max.:	[mm]	37.5	Good
Nominal pitch 1 t	[mm]	34.0 +0.4/-0.2	Good
5 t	[mm]	-	-
11 t	[mm]	374.0 +1.3/-0.4	Good
Diameter at the weld(ds), max.:	[mm]	12.0	Good
Mechanical properties:			
Working load limit(WLL), max.:	[kg]	3000	-
	(drive mechanism g	-	-
Manufacturing proof force(MPF), min.:	[KN]	98	Good
Stress at min. MPF		-	-
Guaranteed breaking force(BF), min.:	[KN]	160	Good
Stress at min. BF		-	-
Total ultimate elongation(A), min.:	[%]	10	Good
Surface hardness/HV3, min.:	[-]	500	Good
/HV5, min.:	[-]	-	-
Hardness /HRC, min.:	[-]	-	-
Case depth,min.:	[mm]	0.22	Good
Bend deflection(f),min.:	[mm]	-	-
Fatigue resistance, min.:	[cycle]	-	-

Packing:	
Weight per meter:	[kg/m] 2.65
Length 1	[meter] 100m-14/pcs
2	[meter] -
Packing	- Steel barrel

I hereby certify above all is true.

issued date: March 29,2010

[Note]

K. Sugimura
 KAZUYUKI SUGIMURA
 Quality Assurance Dept.,
 Chief Inspector

2010-10-11

I-beam calculation sheets

	I-150x75x5.5/9.5	I-200x100x7/10			I-250x125x7.5/12.5				I-300x150x10/18	I-400x150x10/18		I-600x190x13/25
	1TON	1TON	2(1.9)TON	3TON	1TON	2(1.9)TON	3TON	5TON	2(1.9)TON	3TON	5TON	5TON
SPAN L=Cm	300	400	300	250	600	400	400	250	650	700	400	1000
ix (Cm ⁴)	819	2170			5180				9480	24100		98400
ly (Cm ⁴)	57.5	138			337				588	864		2460
zx (Cm ³)	109	217			414				632	1200		3280
zy (Cm ³)	15.3	27.7			53.9				78.4	115		259
S1(Kg-Cm ²)	883	604	863(821)	1124	503	619(589)	683	908	507(484)	588	737	530
δ(Cm)	0.35	0.32	0.26	0.24	0.48	0.26	0.39	0.16	0.48	0.48	0.26	0.59
δ/L	1/854	1/1250	1/1158	1/1030	1/1243	1/1523	1/1025	1/1623	1/1369	1/1470	1/1526	1/1675

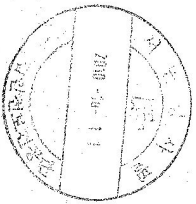

호이스트 스위치

HY-1026 ABB

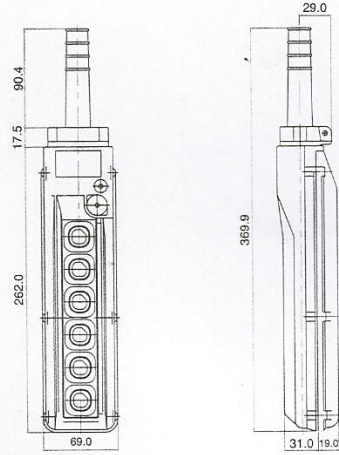
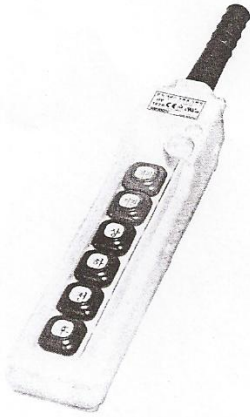

HY-1026 BBB

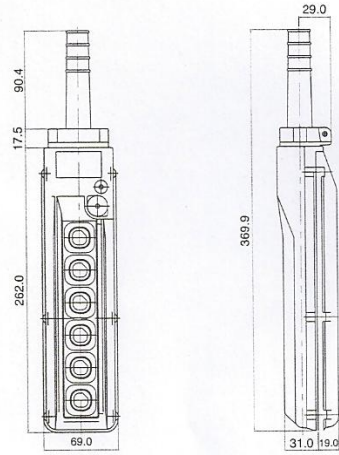
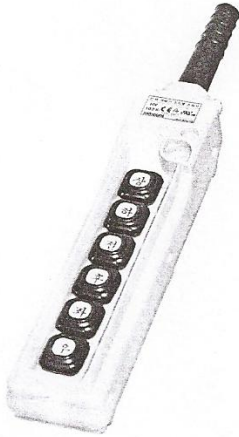

HY-1026 SBBB

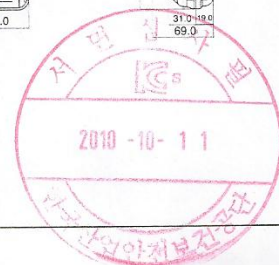
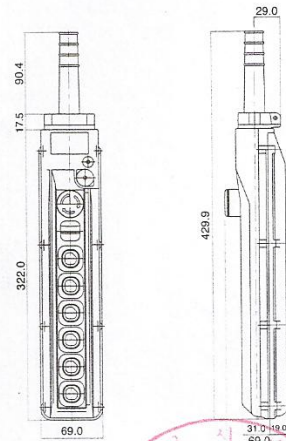
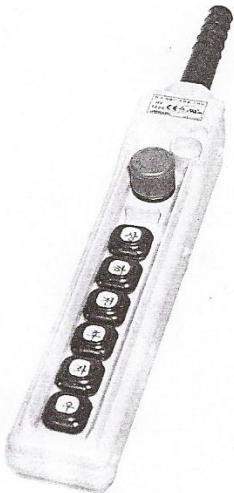

호이스트 스위치

전자 조작용 개폐 스위치 (HOIST SWITCH)

- 전동 HOIST조작용으로 현수식 늘름버튼형 개폐기입니다.
- 방수형의 구조이며 외곽케이스는 기계적 강도 및 전기적 특성이 우수한 수지를 사용하며 가볍고 견고하게 설계되었습니다.
- 스위치 자체에 전원 단절용으로 주회로를 개폐할 수 있는 구조로 되어 있습니다.
- 접점 부분은 1단(1a)이 기본이며, 전동기 속도 제어응에 필요한 2단 접점이 있어 필요 부분에 부착 사용할 수 있도록 설계되어 있습니다.
- 풍부한 버튼 문자판이 준비되어 있어 응도에 맞추어 선택 사용이 용이합니다.
- 소형 및 경량으로 설계되어 경제적입니다.
- 걸고리가 장착되어 사용이 편리합니다.



■ 구조

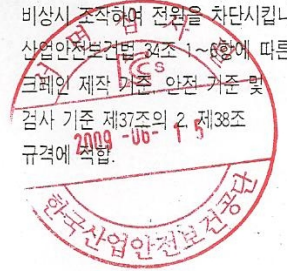
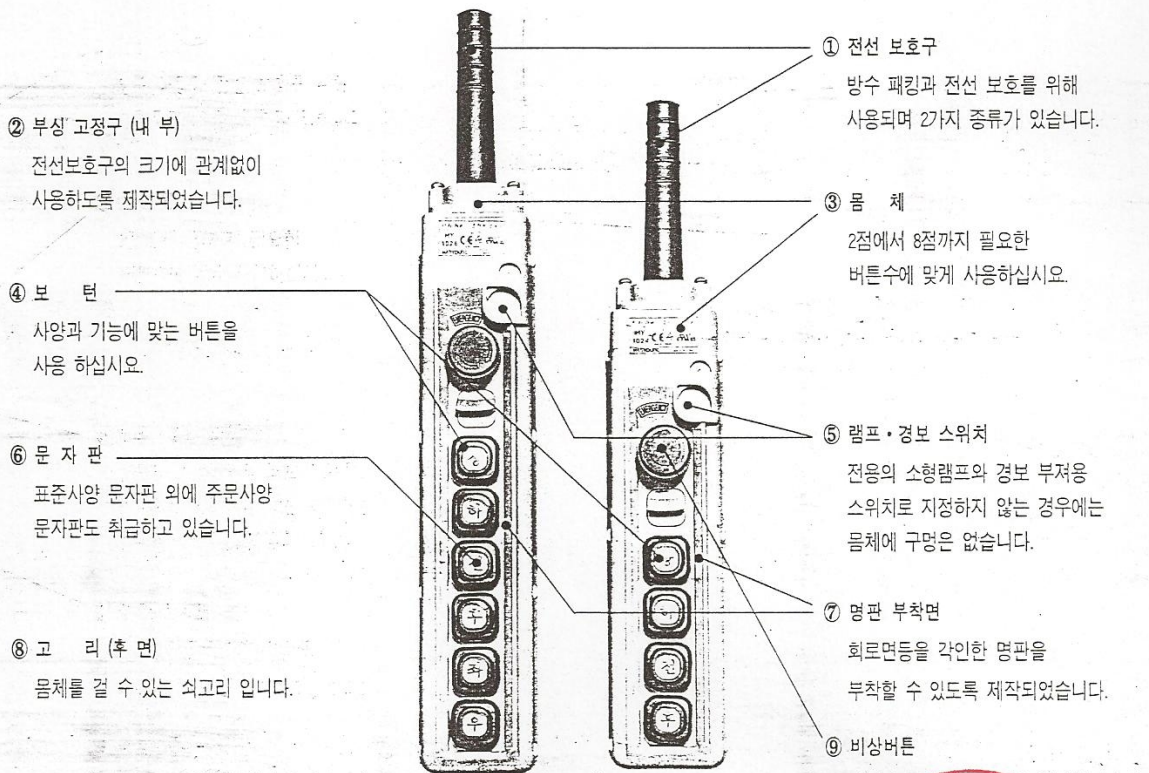

4. 사용전선도면

MODEL : EDSA-1S,2S,3W,5W
EDSM-1S,2S,3W,5W

NO	Commodity	Capacity	QTY	Model No.	Maker
----	-----------	----------	-----	-----------	-------

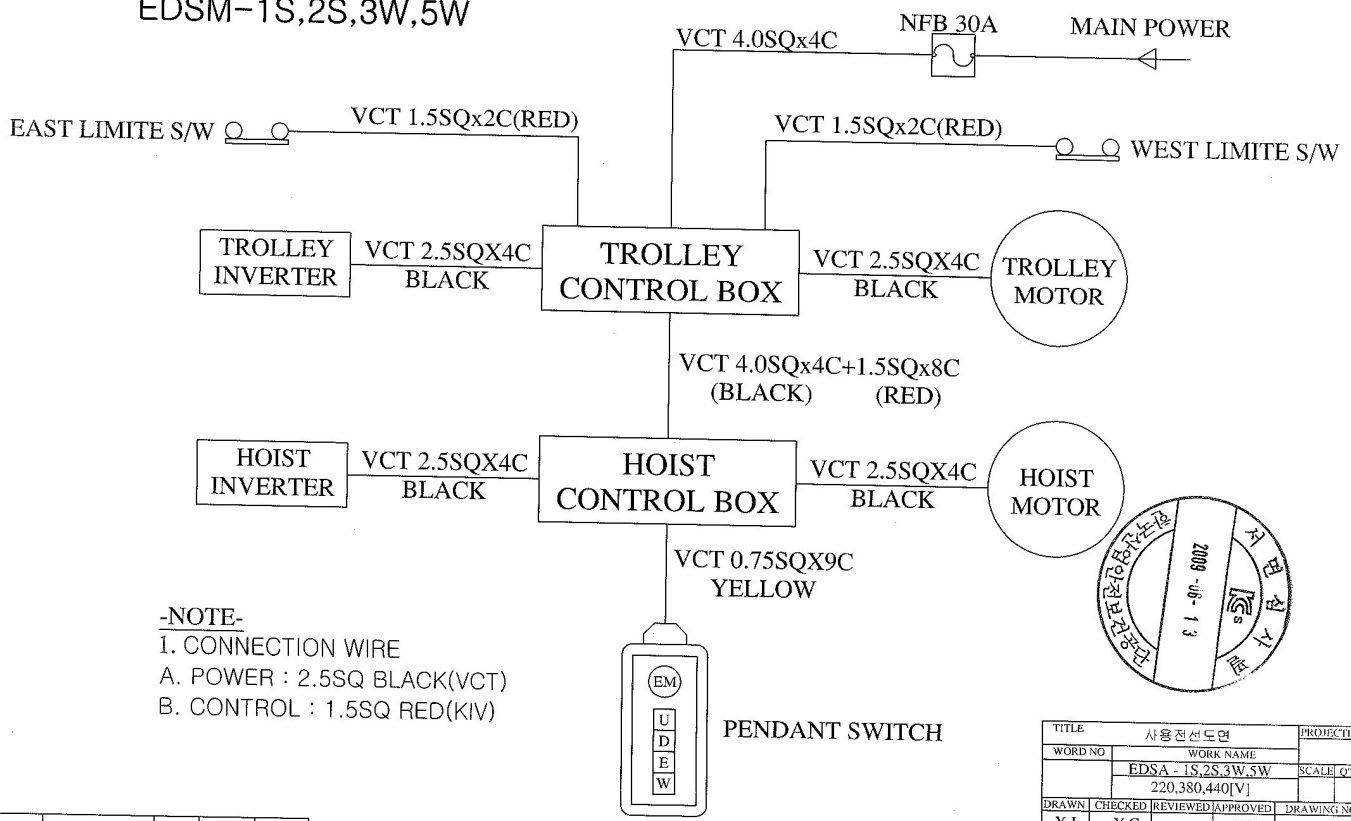

-NOTE-
1. CONNECTION WIRE
A. POWER : 2.5SQ BLACK(VCT)
B. CONTROL : 1.5SQ RED(KIV)

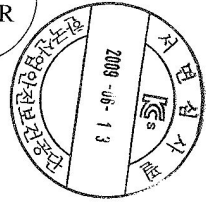

REV. NO	DATE	REVISION DESCRIPTION	DRAWN	CHECKED	APPROVED

TITLE		사용전선도면		PROTECTION
WORD NO	WORK NAME		SCALE QTY	
	EDSA - 1S,2S,3W,5W			
	220,380,440[V]			
DRAWN	CHECKED	REVIEWED	APPROVED	DRAWING NO
Y.J	Y.C		Y.K	EDSA09022
09.05	09.05		09.08	

INoTEC IND. CO., LTD.

3. 접지도면

MODEL : EDSA-1S,2S,3W,5W
EDSM-1S,2S,3W,5W

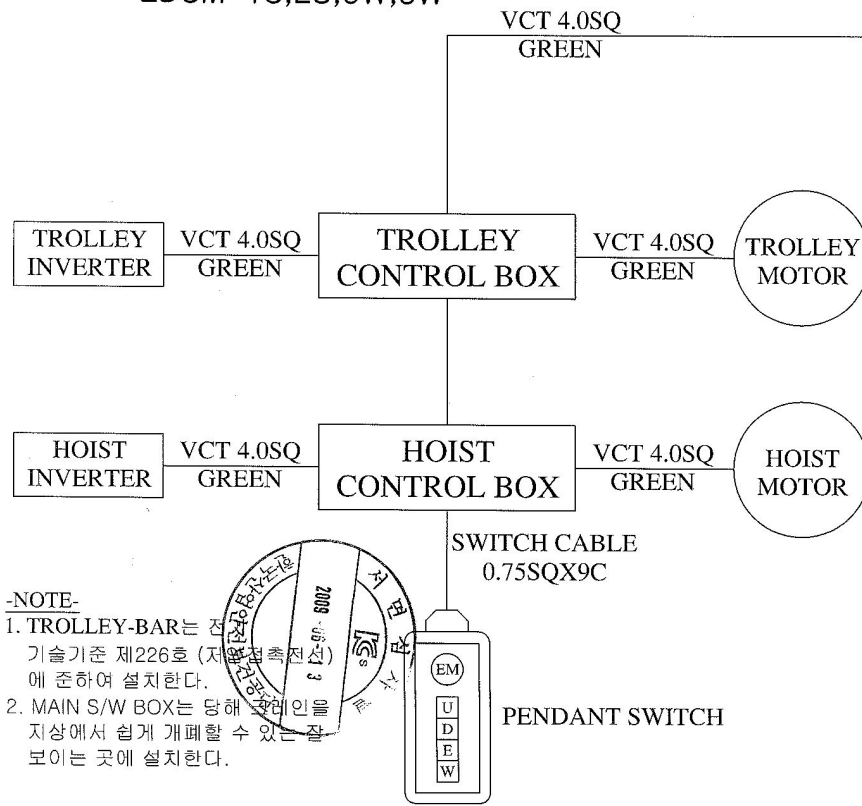

-NOTE-

1. TROLLEY-BAR는 전 기술표준 제226호 (제에 준하여 설치한다.
2. MAIN S/W BOX는 당해 지상에서 쉽게 개폐할 수 있는 보이는 곳에 설치한다.

NO	Commodity	Capacity	QTY	Model No.	Maker
----	-----------	----------	-----	-----------	-------

접지공사 시설편법

1. 전동기의 후레임, 제어반, 레일등은 접지를 해야 하며다음의 규정을 따른다.

접지저항		
3종 접지	400V 이하	100Ω 이하
특별 제3종 접지	400V 초과	10Ω 이하

단 방폭지역은 전압에 관계없이 10Ω 이하일것.

2. 접지전용 트로리선 및 전선은 당해 전기기기, 기구에 대하여 충분한 용량 및 전기적, 기계적 강도를 가져야 한다.
3. 접지선이 외상을 받을 우려가 있는 경우에는 전선관, 합성수지관 등에 넣어야 한다.
4. 접지공사는 지표면에서 최저 75cm 이상의 깊이에 접지봉을 박고 접지봉에는 접지동판을 연결한다.

REV.NO	DATE	REVISION DESCRIPTION	DRAWN	CHECKED	APPROVED
--------	------	----------------------	-------	---------	----------

TITLE		PROJECTION	
2 STEP INVERTER CIRCUIT			
WORD NO		WORK NAME	
EDSA-1S,2S,3W,5W		SCALE QTY	
220,380,440[V]			
DRAWN	CHECKED	REVIEWED	APPROVED
Y.J	Y.C		Y.K
09.05	09.05		09.05
DRAWING NO		EDSA19021	
INoTEC IND. CO., LTD.			

EC Declaration of Conformity

We hereby declare that the following product is in conformity with the essential health and safety requirements of the following EC Directive:

Product : AC Motor
Model : DSMI-12
Manufacture : INOTEC IND. CO., LTD
Address : Siwa Ind. Site 3RA 820, Jungwang-Dong-1370-4
Shheung Gyonggi-Do, Korea
Rated input voltage : AC 220V / 380V / 440V
Rated frequency : 50/60 Hz
Rated input current : 3.3A/1.67A/1.45A
Applicable EU Directive : Low Voltage Directive (73/23/EEC)
EMC Directive (89/336/EEC)

This product is designed and manufactured in accordance with the following standards

Applicable standards : IEC 60034-1: 2004
IEC 60034-11:2004

Year of CE Marking : 2005-12-27

Authorized signature :



Name / Title of signatory :



/ President



INOTEC IND. CO., LTD

EC Declaration of Conformity

We hereby declare that the following product is in conformity with the essential health and safety requirements of the following EC Directive:

Product : AC Motor
Model : DSAI-1.5S
Manufacture : INOTEC IND. CO., LTD
Address : Siwa Ind. Site 3RA 820, Jungwang-Dong 1370-4
Shheung Gyonggi-Do, Korea
Rated input voltage : AC 220V / 380V / 440V
Rated frequency : 50/60 Hz
Rated input current : 17.0A/9.1A/7.86A
Applicable EU Directive : Low Voltage Directive (73/23/EEC)

This product is designed and manufactured in accordance with the following standards

Applicable standards : IEC 60034-1: 2004
IEC 60034-11:2004

Year of CE Marking : 2009-2-27

Authorized signature :

Name / Title of signatory :

장성원 / President

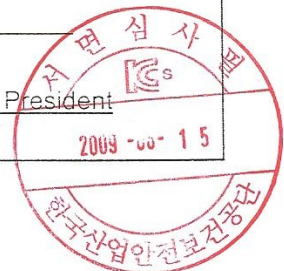

SCHEDULE OF TECHNICAL DATA

1. SERVICE	TRAVERSING
2. MANUFACTURE	DAESAN INOTEC INC.
3. MOTOR MODEL NO.	MT - 1 - 220
4. RATED POWER	0.4 KW x 6 P
5. RATED VOLTAGE AND FREQUENCY	220 V 60 HZ
6. MOTOR TYPE	SQUIRREL CAGE ROTOR YPE
7. RATING	30 MIN
8. LOCATION	IN-DOOR
9. INSULATION CLASS	B
10. DESIGN TEMPERATURE RISE (BY RESISTANCE)	80°C
11. FULL LOAD SPEED	1150 RPM
12. FULL LOAD CURRENT	3.3 A
13. STARTING CURRENT AT RATED VOLTAGE	13.9 A
14. MINIMUM STATING VOLTAGE	198V
15. EFFICIENCY AT 100% RATED LOAD	57.5%
16. POWER FACTOR AT 100% RATED LOAD	54.5%
17. STARTING TORQUE	249%
18. TYPE OF ENCLOSURE	전폐형
19. TYPE OF BEARING	PL : 6202DD · OPL : 6204ZZ
20. MOUNTING	VERTICAL
21. MAXIMUM AMBIENT TEMPURE	40°C
22. BEARING LUBRICATION	GREASE
23. STARTING METHOD	FULL VOLTAGE

REFERENCE

SCHEDULE OF TECHNICAL DATA

1. SERVICE	TRAVERSING
2. MANUFACTURE	DAESAN INOTEC INC.
3. MOTOR MODEL NO.	MT - 1 - 380
4. RATED POWER	0.4 KW x 6 P
5. RATED VOLTAGE AND FREQUENCY	380 V 60 HZ
6. MOTOR TYPE	SQUIRREL CAGE ROTOR YPE
7. RATING	30 MIN
8. LOCATION	IN-DOOR
9. INSULATION CLASS	B
10. DESIGN TEMPERATURE RISE (BY RESISTANCE)	80°C
11. FULL LOAD SPEED	1150 RPM
12. FULL LOAD CURRENT	1.7 A
13. STARTING CURRENT AT RATED VOLTAGE	7.6 A
14. MINIMUM STATING VOLTAGE	342V
15. EFFICIENCY AT 100% RATED LOAD	53.0%
16. POWER FACTOR AT 100% RATED LOAD	51.0%
17. STARTING TORQUE	249%
18. TYPE OF ENCLOSURE	전폐형
19. TYPE OF BEARING	PL : 6202DD OPL : 6204ZZ
20. MOUNTING	VERTICAL
21. MAXIMUM AMBIENT TEMPURE	40°C
22. BEARING LUBRICATION	GREASE
23. STARTING METHOD	FULL VOLTAGE

REFERENCE

SCHEDULE OF TECHNICAL DATA

1. SERVICE	TRAVERSING
2. MANUFACTURE	DAESAN INOTEC INC.
3. MOTOR MODEL NO.	MT - 1 - 440
4. RATED POWER	0.4 KW x 6 P
5. RATED VOLTAGE AND FREQUENCY	440 V 60 HZ
6. MOTOR TYPE	SQUIRREL CAGE ROTOR YPE
7. RATING	30 MIN
8. LOCATION	IN-DOOR
9. INSULATION CLASS	B
10. DESIGN TEMPERATURE RISE (BY RESISTANCE)	80°C
11. FULL LOAD SPEED	1150 RPM
12. FULL LOAD CURRENT	1.5 A
13. STARTING CURRENT AT RATED VOLTAGE	6.5 A
14. MINIMUM STATING VOLTAGE	396V
15. EFFICIENCY AT 100% RATED LOAD	55.3%
16. POWER FACTOR AT 100% RATED LOAD	57.2%
17. STARTING TORQUE	249%
18. TYPE OF ENCLOSURE	전폐형
19. TYPE OF BEARING	PL : 6202DD OPL : 6204ZZ
20. MOUNTING	VERTICAL
21. MAXIMUM AMBIENT TEMPURE	40°C
22. BEARING LUBRICATION	GREASE
23. STARTING METHOD	FULL VOLTAGE

REFERENCE

SCHEDULE OF TECHNICAL DATA

1. SERVICE	HOISTING
2. MANUFACTURE	DAESAN INOTEC INC.
3. MOTOR MODEL NO.	DSAI - 1.5S - 220
4. RATED POWER	3.5 KW x 4 P
5. RATED VOLTAGE AND FREQUENCY	220 V 60 HZ
6. MOTOR TYPE	SQUIRREL CAGE ROTOR YPE
7. RATING	30 MIN
8. LOCATION	IN-DOOR
9. INSULATION CLASS	B
10. DESIGN TEMPERATURE RISE (BY RESISTANCE)	80°C
11. FULL LOAD SPEED	1750 RPM
12. FULL LOAD CURRENT	17.0 A
13. STARTING CURRENT AT RATED VOLTAGE	76.5 A
14. MINIMUM STATING VOLTAGE	198 V
15. EFFICIENCY AT 100% RATED LOAD	75.2%
16. POWER FACTOR AT 100% RATED LOAD	79.5%
17. STARTING TORQUE	238%
18. TYPE OF ENCLOSURE	전폐형
19. TYPE OF BEARING	PL : 6205DD OPL : 6008ZZ
20. MOUNTING	VERTICAL
21. MAXIMUM AMBIENT TEMPURE	40°C
22. BEARING LUBRICATION	GREASE
23. STARTING METHOD	FULL VOLTAGE

REFERENCE

SCHEDULE OF TECHNICAL DATA

1. SERVICE	HOISTING
2. MANUFACTURE	DAESAN INOTEC INC.
3. MOTOR MODEL NO.	DSAI - 1.5S - 380
4. RATED POWER	3.5 KW x 4 P
5. RATED VOLTAGE AND FREQUENCY	380 V 60 HZ
6. MOTOR TYPE	SQUIRREL CAGE ROTOR YPE
7. RATING	30 MIN
8. LOCATION	IN-DOOR
9. INSULATION CLASS	B
10. DESIGN TEMPERATURE RISE (BY RESISTANCE)	80°C
11. FULL LOAD SPEED	1750 RPM
12. FULL LOAD CURRENT	9.1 A
13. STARTING CURRENT AT RATED VOLTAGE	41.2 A
14. MINIMUM STATING VOLTAGE	342 V
15. EFFICIENCY AT 100% RATED LOAD	75.2%
16. POWER FACTOR AT 100% RATED LOAD	82.0%
17. STARTING TORQUE	233%
18. TYPE OF ENCLOSURE	전폐형
19. TYPE OF BEARING	PL : 6205DD OPL : 6008ZZ
20. MOUNTING	VERTICAL
21. MAXIMUM AMBIENT TEMPURE	40°C
22. BEARING LUBRICATION	GREASE
23. STARTING METHOD	FULL VOLTAGE

REFERENCE

SCHEDULE OF TECHNICAL DATA

1. SERVICE	HOISTING
2. MANUFACTURE	DAESAN INOTEC INC.
3. MOTOR MODEL NO.	DSAI - 1.5S - 440
4. RATED POWER	3.5 KW x 4 P
5. RATED VOLTAGE AND FREQUENCY	440 V 60 HZ
6. MOTOR TYPE	SQUIRREL CAGE ROTOR YPE
7. RATING	30 MIN
8. LOCATION	IN-DOOR
9. INSULATION CLASS	B
10. DESIGN TEMPERATURE RISE (BY RESISTANCE)	80°C
11. FULL LOAD SPEED	1750 RPM
12. FULL LOAD CURRENT	7.9 A
13. STARTING CURRENT AT RATED VOLTAGE	38.8 A
14. MINIMUM STATING VOLTAGE	396 V
15. EFFICIENCY AT 100% RATED LOAD	72.4%
16. POWER FACTOR AT 100% RATED LOAD	76.8%
17. STARTING TORQUE	243%
18. TYPE OF ENCLOSURE	전폐형
19. TYPE OF BEARING	PL : 6205DD OPL : 6008ZZ
20. MOUNTING	VERTICAL
21. MAXIMUM AMBIENT TEMPURE	40°C
22. BEARING LUBRICATION	GREASE
23. STARTING METHOD	FULL VOLTAGE

REFERENCE

제 2012-BJ-0009 호



안 전 인 증 서

정호엔지니어링

경기도 광명시 노동사동 440-5

위 사업장에서 제조하는 아래의 품목이 산업안전보건법 제34조 및 같은 법 시행규칙 제58조의4제4항에 따른 안전인증 심사 결과 안전·보건기준에 적합하므로 안전인증표시의 사용을 인증합니다.

_____ 품 목 _____
양중기용 과부하방지장치

_____ 형식·모델/용량·등급/인증번호 _____
형식·모델 용량·등급 인증번호
JDL-100 J-2 12-AV2BJ-0009

_____ 인 증 기 준 _____
방호장치 의무안전인증 고시(고용노동부고시 제2010-36호)

_____ 인 증 조 건 _____
아래 주소에서 생산되는 제품에 한함.
정호엔지니어링, 경기도 광명시 노동사동 440-5

2012년 06월 11일

한국산업안전보건공단 이사장

