



심사결과 통지서

신청인	사업장명 : (주)대산이노텍	사업장관리번호 : 13481628890
	사업자등록번호 : 1348162889	대표자 성명 : 강성원
	소재지 : 충남 공주시 정안면 정안농공단지길 32-32	

안전인증대상 기계·기구명 : 호이스트

형식(규격) : EDL-500 ()

용량(등급) : 0.5Ton [세부용량 :0.5]

「산업안전보건법」 제84조 및 같은 법 시행규칙 제110조에 따라 실시한

[] 예비심사

[] 서면심사

[] 기술능력 및 생산체계 심사

결과가 [] 적 합
[] 부적합

함을 통지합니다.

[] 개별 제품심사

[] 형식별 제품심사

2020년 06월 15일

인증심사원

김호진

대한산업안전협회장



제2020 - BA2001876003호



안 전 인 증 서

(사업장명) (주)대산이노텍

(소재지) 충남 공주시 정안면 정안농공단지길 32-32

위 사업장에서 제조하는 아래의 품목이 「산업안전보건법」 제84조 및 같은 법 시행규칙 제110조의제1항에 따른 안전인증 심사 결과 안전·보건기준에 적합하므로 안전인증표시의 사용을 인증합니다.

품 목

호이스트

형식·모델(용량·등급) / 인증번호

EDL-500(, 0.5 Ton [세부용량 :0.5])/20-BA2AC-50058

인 증 기 준

고용노동부 고시 제2020 - 41호 (위험기계·기구 안전인증 고시)

인 증 조 건

인증유효기간 :

설치장소 : (주)대산이노텍(충남 공주시 정안면 정안농공단지길 32-32)

2020년 07월 30일

대한산업안전협회장

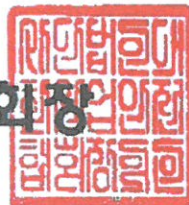

형식 구분



	형 식	속 도	비 고
EDL-500-1 단상	EDL-500-1 HANGER TYPE	1.1~6.4 M/MIN	상 / 하 동작
	EDL-500-1 HOOK TYPE		
	EDL-500-1 CONNECTOR TYPE		
EDL-500-3 삼상	EDL-500-3 HANGER TYPE	1.3~7.6 M/MIN	
	EDL-500-3 HOOK TYPE		
	EDL-500-3 CONNECTOR TYPE		

TECHNICAL SPECIFICATION



DESCRIPTION		500 KG SUSPENSION HOIST	
TYPE		EDL - 500 SUSPENSION TYPE	
RATED LOAD		500 [KG]	
TESTING LOAD		625 [KG]	
LIFT		최대 50 [M] (기본 4 [M])	
SPEED & MOTOR	HOISTING (M/MIN)	1.1~6.4 / 1.3~7.6	0.75[Kw] × 4P
BRAKE SYSTEM	HOISTING	CONE BRAKE	
ELECTRIC SPECIFICATION	POWER SOURCE	AC 1PH 60[Hz] 220[V]/3PH 60[Hz] 220,380,440,460[V]	
	CONTROL SOURCE	AC 110[V]	
	LIMIT SWITCH	TWO STEP LIMIT SWITCH	
	OVER LOAD LIMITER	ELECTRICAL TYPE.	
	EM. STOP DEVICE	EMERGENCY STOP BUTTON	
LOAD CHAIN	∅ 5.0 × P15.0 < 1 FALL >		
TRAVERSING POWER SYSTEM		-	
MAX AMBIENT TEMPERATUE		40[℃]	
RATING		20 / 30[min]	
AREA CLASSIFICATION		INDOOR	
CONTROL METHOD		BY PENDANT PUSH BUTTON S/W	
PAINTING COLOR		MUNSELL NO EX8816D YELLOW, MUNSELL CODE N2.0 BLACK	
방폭 유무		비방폭	

NO	DESCRIPTION	MAT'L	Q'TY	WT(kg)	REMARKS

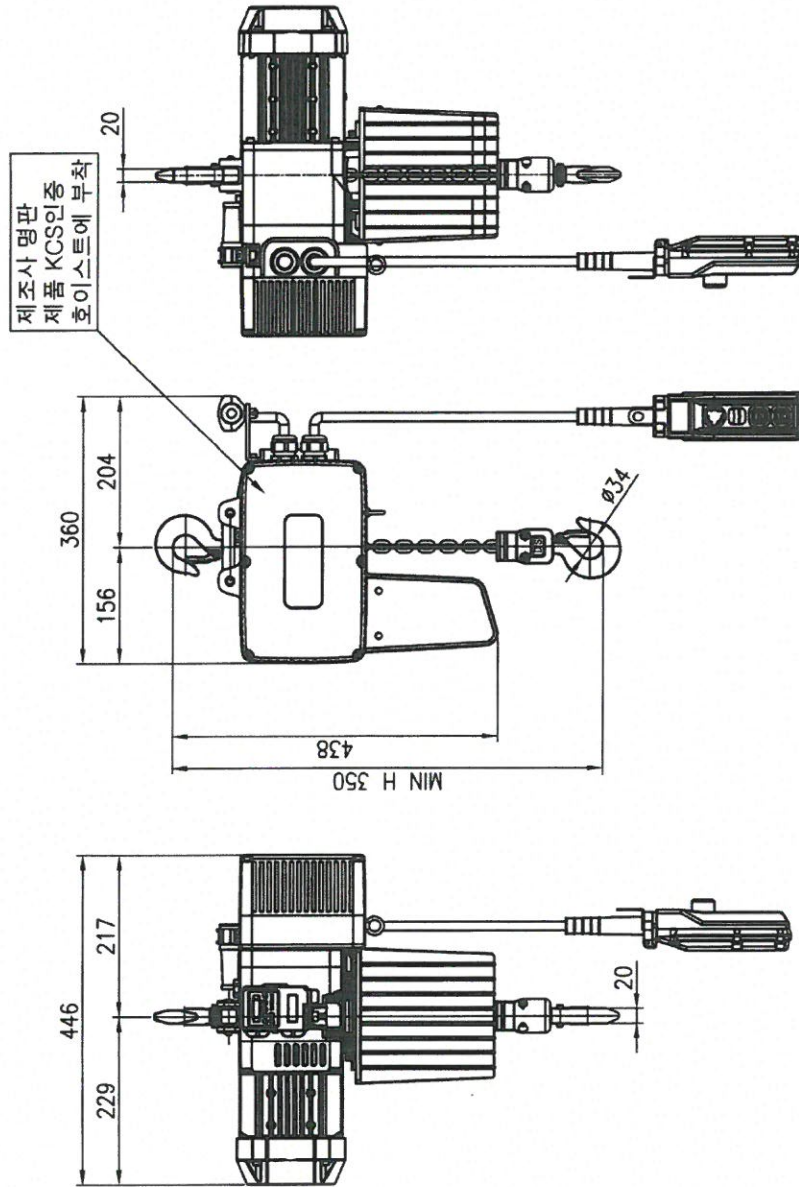

SPECIFICATION	
RATED LOAD	500 KG
TESTING LOAD	625 KG
LIFTING HEIGHT	최대 50 M (기본 4 M)
HOISTING SPEED	1.1~6.4/1.3~7.6 M/MIN
MOTOR	0.75 KW x 4P x 1 SET
POWER SUPPLY	AC 220V x 1φ x 60Hz
OPERATING METHOD	P.B type ON . FL
WEIGHT	70 KG
LOAD CHAIN FALL	ø5.0 x P15.0 x 1
AREA CLASSIFICATION	INDOOR

* 점검시 안전한 사다리 등 사용할 것.

TITLE		EDL-500KG CHAIN HOIST		PROJECTION
WORK NO	MODEL NO	DL-500 HOOK TYPE	SCALE	1/1
DRAWN	CHECKED	REVIEWED	APPROVED	MODEL NO
김수환	-	이학재	신우영	EDL-500-H
2019.11.15	-	2019.11.15	2019.11.15	

REV.NO	DATE	REVISION DESCRIPTION	DRAWN	CHECKED	APPROVED

2020-06-15

10/371

DAESAN INOTECH INC

NO	DESCRIPTION	MAT'L	QTY	WT(kg)	REMARKS

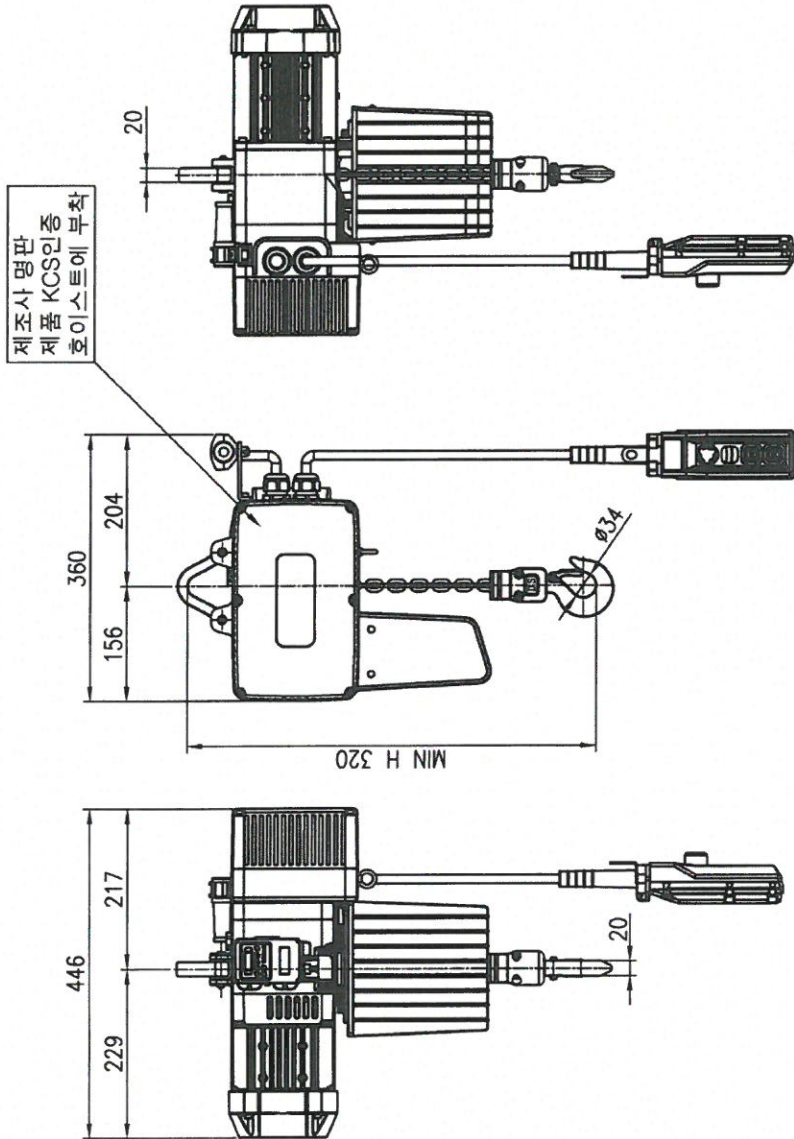

SPECIFICATION	
RATED LOAD	500 KG
TESTING LOAD	625 KG
LIFTING HEIGHT	최대 50 M (기본 4 M)
HOISTING SPEED	1.1~6.4/1.3~7.6 M/MIN
MOTOR	0.75 KW x 4P x 1 SET
POWER SUPPLY	AC 220V x 1Ø x 60Hz
OPERATING METHOD	P.B type ON . FL
WEIGHT	70 KG
LOAD CHAIN FALL	Ø5.0 x P15.0 x 1
AREA CLASSIFICATION	INDOOR

* 점검시 안전한 사다리 등 사용할 것.

TITLE		EDL-500KG CHAIN HOIST		PROJECTION	
WORK NO	MODEL NO	EDL-500-HANGER TYPE		SCALE	QTY
				1/1	1
DRAWN	CHECKED	REVIEWED	APPROVED	MODEL NO	
김수환	-	이한재	선우영구	EDL-500-R	
2019.11.15	-	2019.11.15	2019.11.15		
DAESAN INOTECH INC					

2020-06-15

11/371

REV. NO	DATE	REVISION DESCRIPTION	DRAWN	CHECKED	APPROVED

NO	DESCRIPTION	MAT'L	QTY	WT(kg)	REMARKS

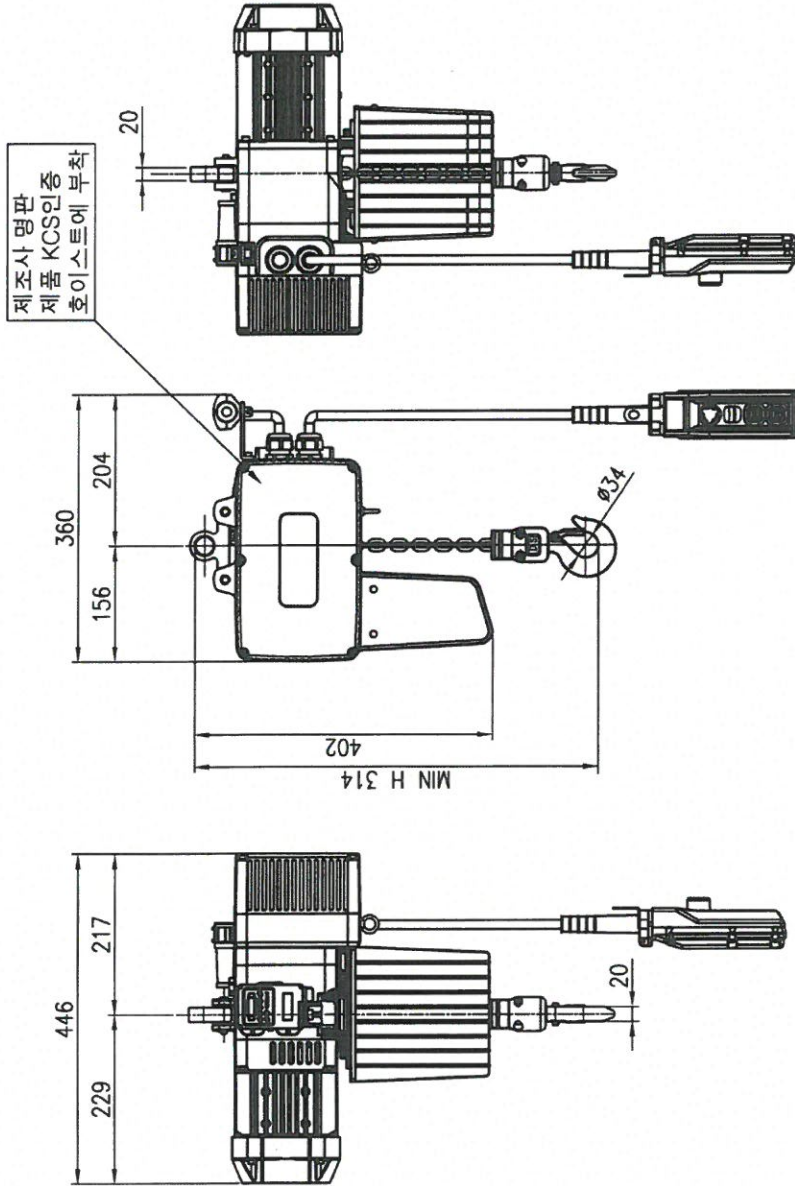

SPECIFICATION	
RATED LOAD	500 KG
TESTING LOAD	625 KG
LIFTING HEIGHT	최대 50 M (기본 4 M)
HOISTING SPEED	1.1~6.4/1.3~7.6 M/MIN
MOTOR	0.75 KW x 4P x 1 SET
POWER SUPPLY	AC 220V x 1φ x 60Hz
OPERATING METHOD	P.B type ON . FL
WEIGHT	70 KG
LOAD CHAIN FALL	φ5.0 x P15.0 x 1
AREA CLASSIFICATION	INDOOR

* 점검시 안전한 사다리 등 사용할 것.

TITLE		EDL-500KG CHAIN HOIST		PROJECTION
WORK NO	MODEL NO	EDL-500 CONNECTOR TYPE	SCALE	QTY
			1/1	1
DRAWN	CHECKED	REVIEWED	APPROVED	MODEL NO
김수환	-	이한재	신우영규	EDL-500-C
2019.11.15	-	2019.11.16	2019.11.15	
DAESAN INOTECH INC				

2020-06-15

12/371

REV. NO	DATE	REVISION DESCRIPTION	DRAWN	CHECKED	APPROVED

DRAWING NO.	DESCRIPTION	REVISION	REVISION NOTATION	DESIGNER	DATE
EDL500E01	DRAWING LIST	-	0	Hyeon-Jin.Kim	2020.03.16
EDL500E02	SYMBOL LIST	-	0	Hyeon-Jin.Kim	2020.03.16
EDL500E03	HOIST CONTROL COMPONENT	-	0	Hyeon-Jin.Kim	2020.03.16
EDL500E04	SCHEMATIC DIAGRAM	-	0	Hyeon-Jin.Kim	2020.03.16
EDL500E05	CIRCUIT DIAGRAM	-	0	Hyeon-Jin.Kim	2020.03.16
EDL500E06	LOAD LIMITER SETTING , SAFETY DATA	-	0	Hyeon-Jin.Kim	2020.03.16

MOTOR	모델	상 (Phase)	정격하중 (kg)	모터용량 (Kw x 극수)	전압 전류 V(A)	전원선 사이즈
HOIST	EDL	3φ	500kg	0.75 x 4P	220V(5.7A)	2.5SQ x 4C
	EDL	3φ	500kg	0.75 x 4P	380V(3.0A)	2.5SQ x 4C
	EDL	3φ	500kg	0.75 x 4P	4.40V(2.7A)	2.5SQ x 4C
	EDL	3φ	500kg	0.75 x 4P	4.60V(2.5A)	2.5SQ x 4C

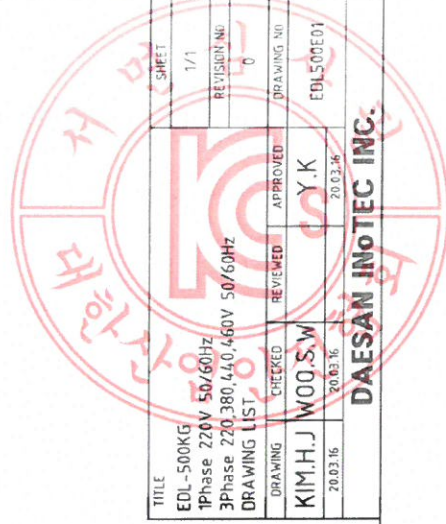

TITLE	EDL-500KG	SHEET	1/1
1Phase 220V 50/60Hz		REVISION NO.	0
3Phase 220,380,440,460V 50/60Hz		DRAWING LIST	
DRAWING	CHECKED	REVIEWED	APPROVED
DRAWING NO.	20.03.16	20.03.16	20.03.16
DESIGNER	KIM.H.J	CHECKER	WOO.S.W
APPROVER	Y.K	REVIEWER	Y.K
DRAWING NO.	EDL500E01		

DAESAN INOTEC INC.

NO	SYMBOL	DESCRIPTION
1		Three Pole Circuit Breaker
2		Three Pole Contactor (NO)
3		Normally Open Contactor (NO)
4		Normally Closed Contactor (NC)
5		Emergency Push Button (NC)
6		Push button (NO) Mechanical Interlock
7		2 Layer Push button (NO) Mechanical Interlock
8		Limit Switch (NC) Cam Operating
9		Limit Switch (NC) Roller
10		Limit Switch (NC) Micro Switch
11		Self Operating Thermal Switch (NC) Motor Thermal Protector
12		Contactor Coil
13		Fuse
14		Resistor
15		Capacitor

NO	SYMBOL	DESCRIPTION
16		Current Transformer
17		Rectifier
18		Earth
19		Terminal Block
21		3P Thermal Relay
22		Jack & Plug
23		Transformer
24		Solenoid Brake Coil Only DC100V or DC200V
25		Solenoid Brake Coil DC100/200V DC100V Wiring
26		Solenoid Brake Coil DC100/200V DC200V Wiring

NO	SYMBOL	DESCRIPTION
27		3 Phase Motor Only 220V or 440V or 460V
28		3 Phase Motor 220/380V 220V Wiring
29		3 Phase Motor 220/380V 380V Wiring
30		3 Phase Motor 230/460V 230V Wiring
31		3 Phase Motor 230/460V 460V Wiring
32		1 Phase Motor 110/220V

TITLE	EDL-500KG	SHEET	1/1
REVISION	1Phase 220V 50/60Hz	REVISION NO	0
SYMBOL LIST	3Phase 220,380,440,460V 50/60Hz	DRAWING NO	EDL-500E02
DRAWING	CHECKED	APPROVED	
DRAWN	KIM.H.J	Y.K	
DATE	20.03.16	DATE	20.03.16

DAESAN INOTECH INC.

2020-06-15

41/371

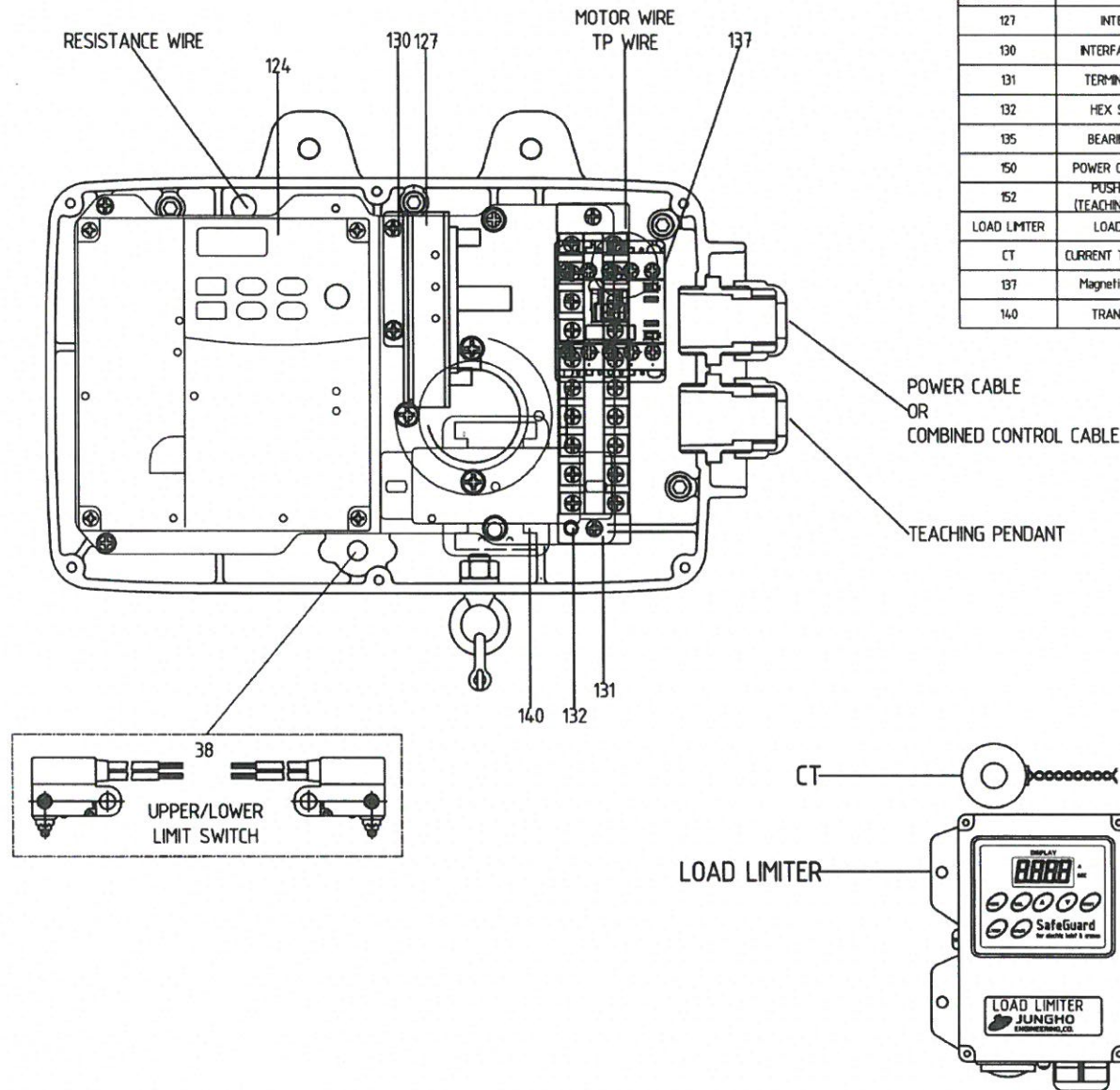

PART NO	COMMODITY	STANDARD	CAPACITY	QTY	MAKE*	REMARK
38	LIMIT SWITCH	D2HW-C202MR	0.1A-125VAC	2	OMR	UPPER , LOWER LIMIT SWITCH
66	BRAKING RESISTANCE	ULH60	40Ω	1	RARA ELECTRONIC	Machine Screw S/W M5x10
72	BRAKING RESISTANCE CABLE	VCT	2.550x2C	0.5M	KI CABLE	-
124	INVERTER	SOHO15NC02Y SOHO15NC04Y	15KW 200-240VAC 15KW 380-480VAC	1	SEDOHO ELECTRIC	Machine Screw S/W. P/W M4x12 (P/W Ø8)
127	INTERFACE	EDL	-	1	DAESAN INOTEC	-
130	INTERFACE BOARD	EDL	-	1	DAESAN INOTEC	Machine Screw S/W M5x10
131	TERMINAL BLOCK	KTB1-02010	20A 600VAC	1	HANYOUNG NUX	Machine Screw S/W M4x12
132	HEX STAY PIN	65mm	65mm	2	DAESAN INOTEC	-
135	BEARING COVER	-	-	1	DAESAN INOTEC	-
150	POWER CABLE ASS'Y	VCT	2.550x4E	1.5M	KI CABLE	-
152	PUSH BUTTON (TEACHING PENDANT)	HY-P1022S	6A-250VAC	1	HANYOUNG NUX	+ TEACHING PENDANT COVER
LOAD LIMITER	LOAD LIMITER	JDL5-70	DC 24V	1	JUNGHO ENG	Machine Screw S/W. P/W M4x12 (P/W Ø10)
CT	CURRENT TRANSFORMER	C-20	80 : 0.08A	1	JUNGHO ENG	-
137	Magnetic Contactor	GMC-12M	AC 110	1	LSIS	-
140	TRANSFORMER	35VA	220,380,440V -110V	1	DECHUANG TRANSFORMER	Machine Screw S/W. P/W M4x8 (P/W Ø10)

TITLE				SHEET	
EDL-500KG				1/1	
3Phase 220,380,440,460V 50/60Hz				REVISION NO	
BASIC CONTROL COMPONENT				0	
HOIST CONTROL BOX				DRAWING NO	
DRAWING		CHECKED	REVIEWED	APPROVED	DRAWING NO
WOO.S.W				Y.K	EDL500E03
20.06.08				20.03.16	

DAESAN INoTEC INC.

GROUNDING

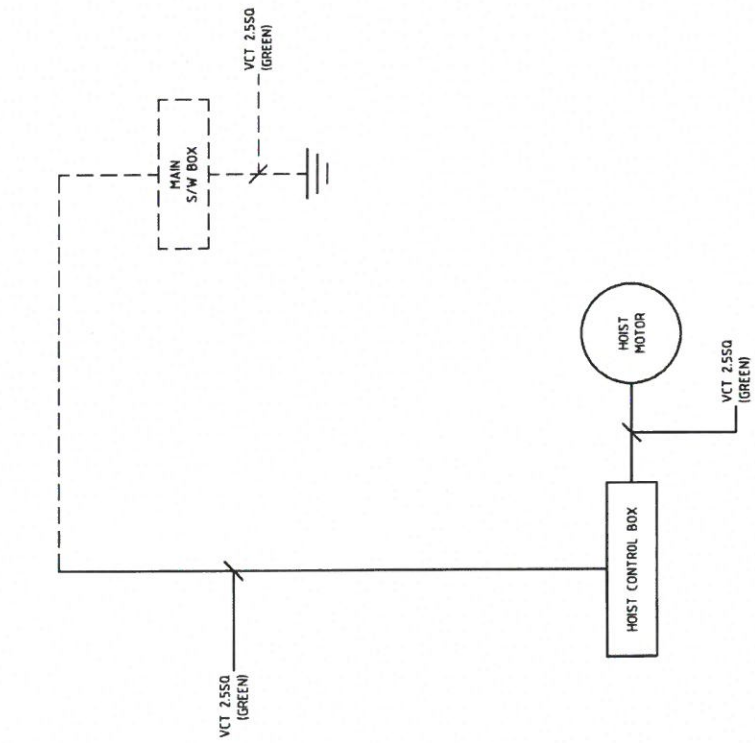

--- OWNER SCOPE
 — DAESAN SCOPE

CABLE

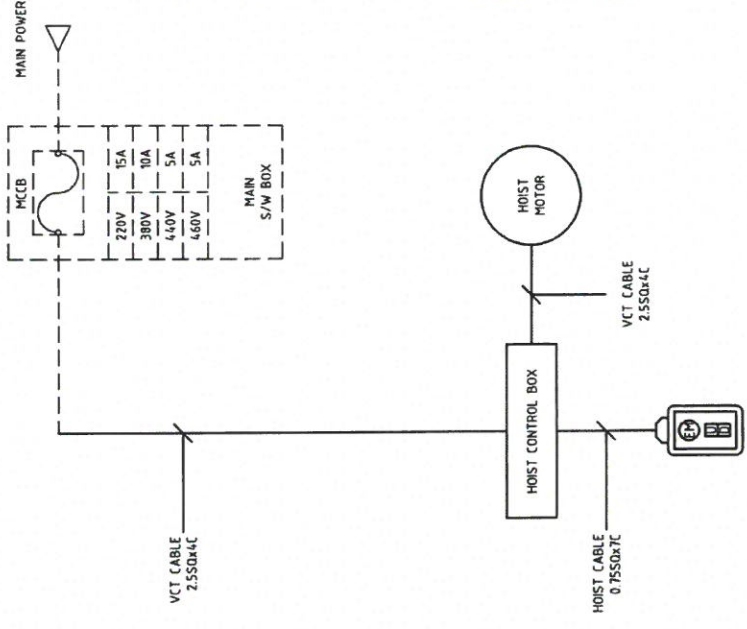

--- OWNER SCOPE
 — DAESAN SCOPE

-NOTE-
 1. CONNECTION WIRE
 A. POWER : KW 2.55Q(BLACK)
 B. CONTROL : KW 1.55Q(RED)

■ 접지공사 시설행법

1. 전동기의 프레임, 제어반, 레일등은 접지를 해야 하며 다음의 규정을 따른다.

접지 저항

3종 접지	400V 이하	100Ω 이하
특별 제3종 접지	400V 초과	10Ω 이하

단 방폭지역은 전압에 관계없이 10Ω 이하일 것.

2. 접지선용 트롤리선 및 전선은 당해 전기기기, 기구에 대하여 충분한 용량 및 전기적, 기계적 강도를 가져야 한다.
3. 접지선이 외상을 받을 우려가 있는 경우에는 전선관, 합성 수지관 등에 넣어야 한다.
4. 접지공사는 지표면에서 최저 75Cm 이상의 깊이에 접지봉을 박고 접지봉에는 접지 동판을 연결한다.

■ NOTE

1. TROLLEY-BAR는 전기 기술기준 제226호(저압접촉전선)에 준하여 설치 한다.
2. MAIN S/W BOX는 당해 크레인을 지상에서 쉽게 개폐할 수 있는 잘 보이는 곳에 설치 한다.

TITLE	EDL-500KG	SHEET	1/1
REVISION NO			
SHCEMATIC DIAGRAM	3Phase 220V 50/60Hz 3Phase 220,380,440,460V 50/60Hz	CHECKED	0
DRAWING	KIM,H.J	REVIEWED	
DRAWING NO	WOO,S.W	APPROVED	
	20.03.16	Y.K	EDL500E04
	20.03.16		20.03.16

DAESAN INOTECH INC.

2020-06-15

43/371

CONSUMER

HOIST CONTROL

PUSH BUTTON

MCCB	
220V	15A
380V	10A
440V	5A
460V	5A

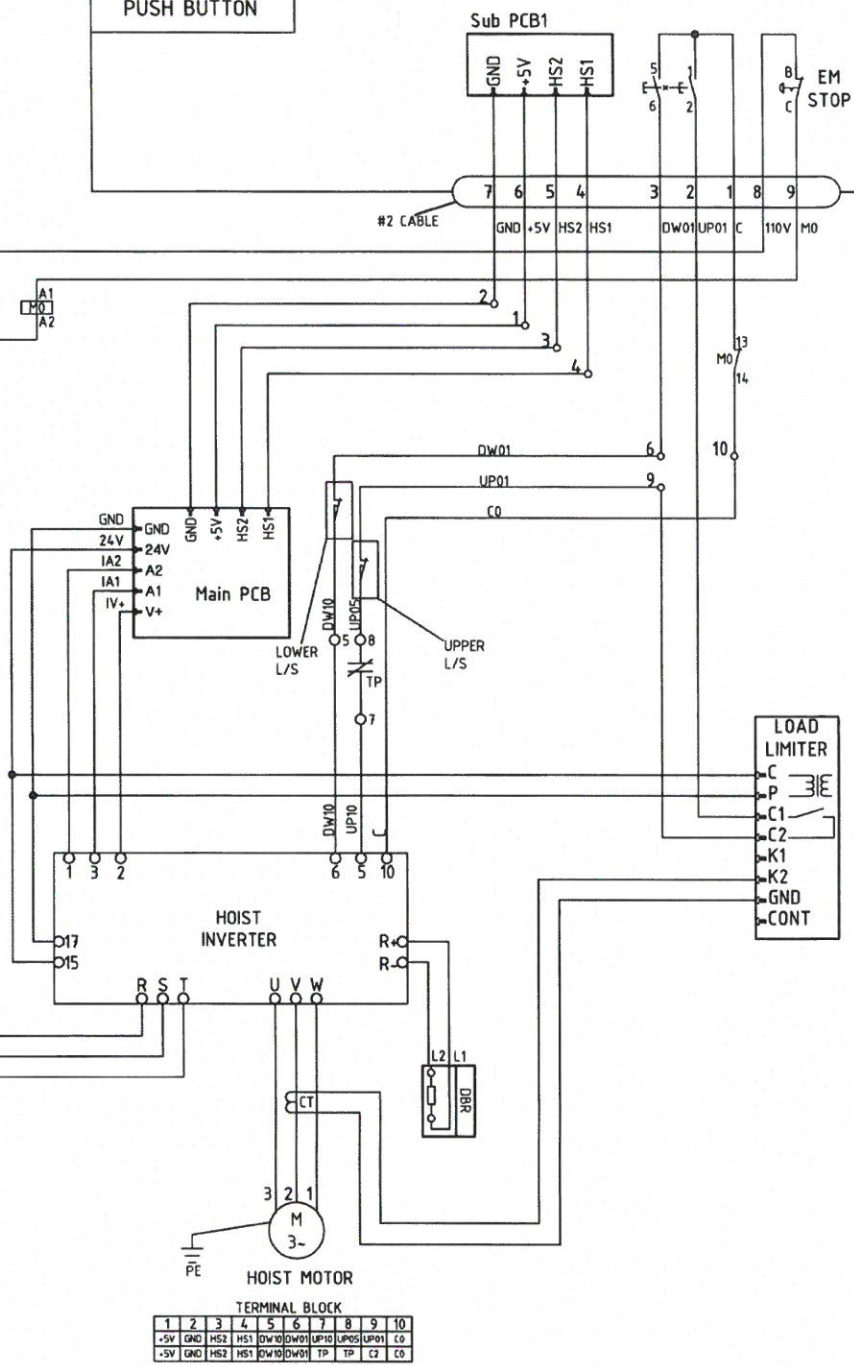
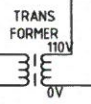
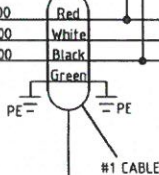
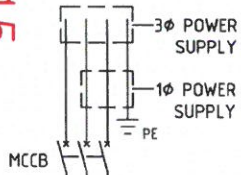

TERMINAL BLOCK

1	2	3	4	5	6	7	8	9	10
-5V	GND	HS2	HS1	DW10	DW01	UP10	UP01	CO	
-5V	GND	HS2	HS1	DW10	DW01	TP	C2	CO	

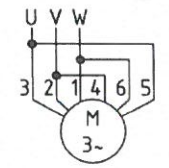

HOIST MOTOR
CIRCUIT DIAGRAM OF 220,230V

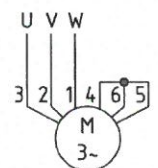

HOIST MOTOR
CIRCUIT DIAGRAM OF 380V

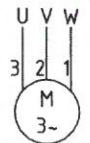

HOIST MOTOR
CIRCUIT DIAGRAM OF 440,460,480V

NOTE

1. POWER WIRE : 2.5SQ BLACK
2. CONTROL WIRE : 1.5SQ RED
3. EARTH WIRE : 2.5SQ GREEN

MOTOR SPEC.

1. HOIST : 3φ 0.75kW 4P

DYNAMIC BRAKE RESISTOR SPEC.

1. ULH60 4Ω

INVERTER SPEC.

1. HOIST
- SOHO 1.5NC02Y (200-230V)
- SOHO 1.5NC04Y (380-460V)

ABBREVIATION

- CT : CURRENT TRANSFORMER
- MCCB : MOLDED CASE CIRCUIT BRAKER
- DBR : DYNAMIC BRAKING RESISTOR
- TP : THERMAL PROTECTOR
- EM : EMERGENCY
- RD : RED
- BK : BLACK
- WT : WHITE
- GR : GREEN
- YL : YELLOW

CABLE

- #1. POWER CABLE
- 2.5SQx4C(RD,WT,BK,GR)
- #2. HOIST CABLE
- 0.75SQx9C(YL)

TITLE	EDL-500KG (LOAD LIMITER)	SHEET	1/1
1Phase	220V 50/60Hz	REVISION NO	0
3Phase	220,380,440,460V 50/60Hz	DRAWING NO	EDL500E05
CIRCUIT DIAGRAM			
DRAWING	CHECKED	REVIEWED	APPROVED
KIM.H.J	WOO.S.W	Y.K	
20.06.09	20.06.09	20.06.09	

DAESAN INOTEC INC.

LOAD LIMITER SETTING DATA								
Motor	Motor pole	Weight	Power source	Load limiter setting data				
				start Delay time	Overload time	Reset time	L current	H current
0.75kw	4	0.55 ton (110%)	220V 60Hz	0.7	0.7	0.3	4.80	4.80
			380V 60Hz	0.7	0.7	0.3	3.04	3.04
			440V 60Hz	0.7	0.7	0.3	2.60	2.60
			460V 60Hz	0.7	0.7	0.3	2.70	2.70

1. LOAD LIMITER 설정은 무게 110%의 값으로 함.
 2. 위 DATA는 대산이노텍 공장내부 전압 기준으로 설정됨.
 3. 각각의 전동기 특성 및 현장 조건에 따라 전류의 설정치는 약간의 변동이 발생할 수 있음.

SAFETY	
<p>※감전 방지를 위한 외함구조</p> <p>1. 숙련자만이 취급할 수 있도록 키 등을 부착하거나 고정식 덮개의 구조일 것.</p> <p>2. 외함 개방시 충전 부분이 차단 되도록 할 것.</p> <p>3. 외함 개방 후 충전 되어 있는 부분은 IP2X 이상의 직접접촉 방호가 되어 있을 것.</p>	

CIRCUIT BREAKER							
Power source	Rated current (A)		Total rated current (A)		Circuit breaker		
	Hoist motor (I _n)	Control (I _c)	I _n +I _c	I _n ×250%	AF (Ampere Frame)	AT (Ampere Trip)	
220V 60Hz	5.7	1.0	6.7	16.8	30AF	15AT	
380V 60Hz	3.0	1.0	4	10	30AF	10AT	
440V 60Hz	2.7	1.0	3.7	9.3	30AF	5AT	
460V 60Hz	2.5	1.0	3.5	8.8	30AF	5AT	

※위 표는 각 제품 1대에 대한 권고치임.

※과전류 보호
 가. 과전류 보호를 위하여 각 부품의 정격전류 또는 도체의 허용전류 값 중에서 더 작은 값에 대하여 보호되어야 한다.
 나. 퓨즈의 정격전류 또는 기타 과전류 보호장치의 전류 설정값은 가능한 낮게 선정하되 예상되는 과전류(전동기 기동 전류 등)에 적절하여야 한다.
 다. 과전류 보호용으로 차단기 또는 퓨즈를 설치시 차단용량은 해당 전동기 등의 정격전류에 대하여 **차단기는 250%**, 퓨즈는 300% 이하하여야 한다.
 라. 과전류차단장치는 각 분기회로마다 설치되어야 한다.
 마. 전원전압에 직접 접속되는 제어회로 및 제어회로 변압기는 과전류 보호가 되어야 한다.
 바. 제어용변압기 2차측 회로의 과전류보호장치는 접지회로가 아닌 다른 단에 설치되어야 한다.

WIRE COLOR	
<p>※전선 및 조작 버튼의 색상</p> <p>1. 조작 버튼의 색상</p> <p>빨강색(RED) -----> 비상 스위치 노랑색(YELLOW) -----> 비정상 녹색(GREEN) -----> 정상 청색(BLUE) -----> 의무 흰색,회색 또는 흑색 -----> 지정된 의미 없음</p> <p>2. 표시등의 색상</p> <p>빨강색(RED) -----> 비상 노랑색(YELLOW) -----> 비정상 녹색(GREEN) -----> 정상 청색(BLUE) -----> 의무 흰색,회색 또는 흑색 -----> 지정된 의미 없음</p> <p>3. 전선의 색상</p> <p>검정색(BLACK) -----> 전원선(POWER) 빨강색(RED) -----> 교류제어선(CONTROL) 청색(BLUE) -----> 직류제어선 노랑색(YELLOW) -----> 외부에서 공급되는 연동장치 제어회로 녹색(GREEN) 또는 녹색과 노랑(YELLOW) 혼용 -----> 접지</p>	

TITLE				SHEET	
EDL-500KG				1/1	
1Phase 220V 50/60Hz				REVISION NO	
3Phase 220,380,440,460V 50/60Hz				0	
LOAD LIMITER SETTING, SAFETY DATA				DRAWING NO	
DRAWING		CHECKED	REVIEWED	APPROVED	DRAWING NO
KIM.H.J		WOO.S.W		Y.K	EDL500E06
20.03.16		20.03.16		20.03.16	
DAESAN INoTEC INC.					

NO	DESCRIPTION	SIZE	MAT'L	Q ^T	WT(kg)	REMARKS

PIN 결합형

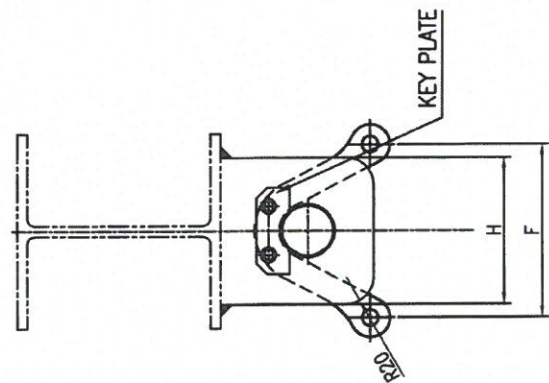

PIN 결합형

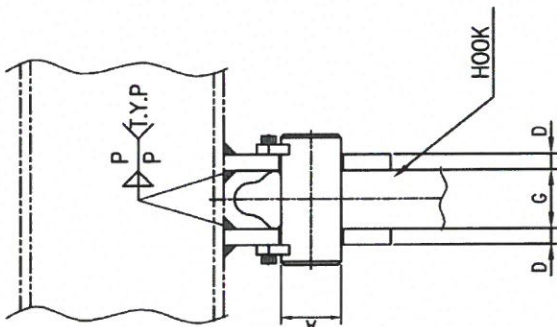

HOOK 길이형

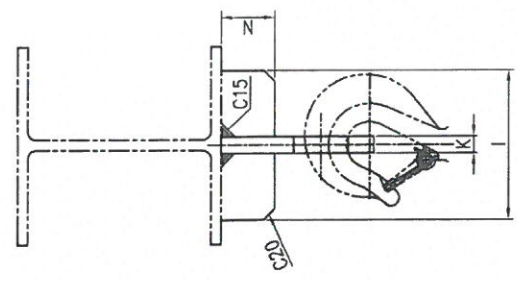
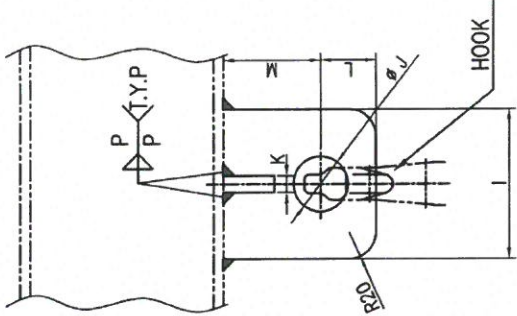

NOTE)

- 1) CONNECTOR 자리에 HOOK 직접취부.
- 2) P : 필렛용접의 각장은 원판두께의 70%로 함.

치수표

구분	치수	A	B	C	D	E	F	G	H	I	J	K	L	M	N
0.5 TON	φ25	120	25	25	8	25	91.5	20	65	100	30	10	35	70	40

* CONNECTING PIN 치수는 당사 표준규격 치수임.

TITLE		DETAIL OF CONNECTOR		PROJECTION
WORK NO	WORK NAME	정지차 HOIST 고장원치 DRAWING	SCALE	1:1
DRAWN	CHECKED	REVIEWED	APPROVED	DRAWING NO
KIM.S.H	LEE.H.J	Y.K	Y.K	EDL000A01
20.04.03	20.04.03	20.04.03	20.04.03	

REV.NO	DATE	REVISION DESCRIPTION	DRAWN	CHECKED	APPROVED

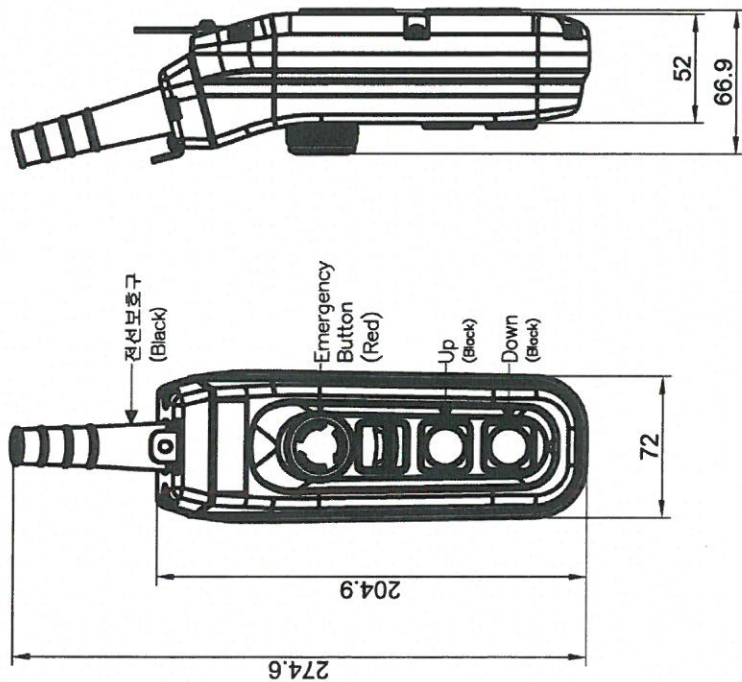

※ 사양

정격 전류	6 A, 250 V a.c.
정격 전압	10 A, 250 V a.c. 비상용 스위치 (푸쉬 록-턴 리셋) 100 VAC (500 V a.c.)
내전압	2000 V a.c. 1분간 (충전부-비충전부 사이)
보호구조	IP-65
재질	케이스 : 고충격용 ABS수지 점접 : AgSnO2
진동 (내구)	10 - 55 Hz 복진폭 1.0 mm
충격 (내구)	500 m/s ²
사용주위 온도	-10 ~ 45 °C
사용주위 습도	45 ~ 85 % R.H.

※ 점접구성

비상용 스위치	1단 스위치	2단 스위치

TITLE		SHEET	
HOIST SWITCH		1/1	
HY-P1024S		REVISION NO	
2 POINT		0	
DRAWING	CHECKED	REVIEWED	APPROVED
KIM,H.J	WOO,S.W		Y.K
20.03.16	20.03.16		20.03.16
DAESAN INOTECH INC.			
		DRAWING NO	
		HY-P1022SB	

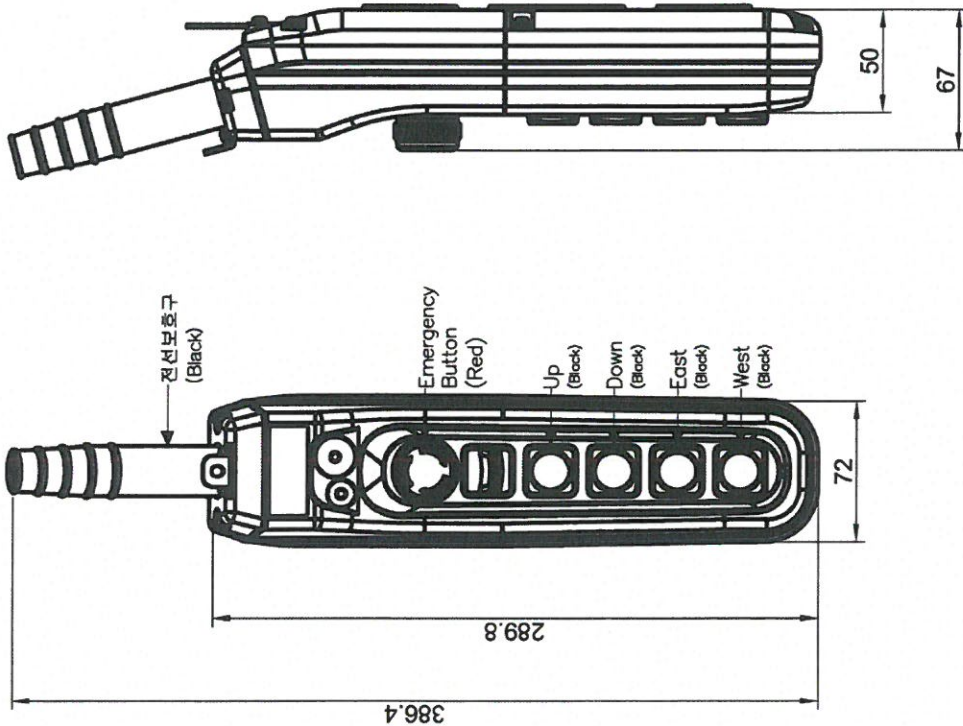

※ 사양

정격 전류	6 A 250 V a.c.
절연 저항	10 A 250 V a.c. 비상용 스위치 (푸쉬 록-턴 리셋) 100 MΩ (500 V a.c.)
내전압	2000 V a.c. 1분간 (충전부-비충전부 사이)
보호구조	IP-65
재질	케이스 : 고충격용 ABS수지 접점 : AgSnO2
진동 (내구)	10 ~ 55 Hz 복진폭 1.0 mm
충격 (내구)	500 m/s ²
사용주위 온도	-10 ~ 45 °C
사용주위 습도	45 ~ 85 % R.H.

※ 점점구성

비상용 스위치	1단 스위치	2단 스위치

TITLE		SHEET	
HOIST SWITCH		1/1	
HY-P1024S		REVISION NO	
4 POINT		0	
DRAWING	CHECKED	REVIEWED	APPROVED
KIM.H.J	WOO.S.W		Y.K
20.03.16	20.03.16		20.03.16
DAESAN INoTEC INC.		DRAWING NO	
		HY-P1024SBB	



안 전 인 증 서

정호엔지니어링

경기도 광명시 노동사동 440-5

위 사업장에서 제조하는 아래의 품목이 산업안전보건법 제34조 및 같은 법 시행규칙 제58조의4제4항에 따른 안전인증 심사 결과 안전·보건기준에 적합하므로 안전인증표시의 사용을 인증합니다.

품 목

양증기용 과부하방지장치

형식·모델/용량·등급/인증번호

형식·모델	용량·등급	인증번호
JDLS-70	J-2	12-AV2BJ-0008

인 증 기 준

방호장치 의무안전인증 고시(고용노동부고시 제2010-36호)

인 증 조 건

아래 주소에서 생산되는 제품에 한함.

정호엔지니어링, 경기도 광명시 노동사동 440-5

2012년 06월 11일

한국산업안전보건공단 이사장



FEC CHAIN
CORPORATION

337 KANAORI-CHO ,MINAMI-KU, HAMAMATSU CITY,
SHIZUOKA PREF.,435-0026 JAPAN
TEL:+81-53-425-4116 , 2162 FAX:+81-53-425-5122

TEST CERTIFICATE

Distributor:	code #: 1080	distributor's name: ASAO & CO., LTD	
Customer:	customer's name:		
Article name: (Application)	Load chain for electric chain hoist		
Spec. standard	<input type="checkbox"/> DIN EN 818-7:2002 , <input type="checkbox"/> JIS B 8812:1999 <input type="checkbox"/> ISO 3077 , <input checked="" type="checkbox"/> FEC		
Material spec.:	SAE15B24(Mn-B steel)		
Finish:	<input checked="" type="checkbox"/> temper-colored, <input type="checkbox"/> zinc-plated, <input type="checkbox"/> coated() <input type="checkbox"/> zinc-phosphated, <input type="checkbox"/> manganese-phosphated <input checked="" type="checkbox"/> oiled, <input type="checkbox"/> no-oiled		
Stamping:	<input checked="" type="checkbox"/> FEC standard, <input type="checkbox"/> customer's request → DAT, JPN , (Lot 1S), FEC8		
Product code#: description: quality type	FCD05015 φ5.0*P15 G80/ type-DAT		
Result			
Dimension:			
Nominal diameter(dn)	[mm]	5.0+0.2/-0.2	Good
Internal width,min.:	[mm]	6.2	Good
external width, max.:	[mm]	17.5	Good
Nominal pitch 1 t	[mm]	15.0+0.29/-0	Good
5 t	[mm]	-	-
11 t	[mm]	165.0+0.78/-0	Good
Diameter at the weld(ds), max.:	[mm]	5.6	Good
Mechanical properties:			
Working load limit(WLL), max.:	[kg]	630	-
(drive mechanism group:)		-	-
Manufacturing proof force(MPF), min.:	[KN]	20	Good
Stress at min. MPF		-	-
Guaranteed breaking force(BF), min.:	[KN]	31.5	Good
Stress at min. BF		-	-
Total ultimate elongation(A), min.:	[%]	10	Good
Surface hardness/HV3, min.:	[-]	500	Good
/HV5, min.:	[-]	-	-
Hardness /HRC, min.:	[-]	-	-
Case depth,min.:	[mm]	0.15	Good
Bend deflection(f),min.:	[mm]	-	-
Fatigue resistance, min.:	[cycle]	-	-
Packing:			
Weight per meter:	[kg/m]		
Length 1	[meter]	10m-1pc	
2	[meter]	-	
Packing	-	Cardboard box	
I hereby certify above all is true.		<i>M. Miwa</i> MASAKI MIWA Quality Assurance Dept., Chief Inspector	
issued date:	April 19,2018		
[Note]			

SPECIFICATION FOR ELECTRIC MOTORS	INTERNAL IDENTIFICATION NO.	PAGE : REV :
TECHNICAL DATA		
1. SERVICE	HOISTING	
2. MANUFACTURE	DAESAN INOTEC INC.	
3. MOTOR MODEL NO.	EDL - 500KG - 220	
4. RATED POWER	0.75 KW x 4 P	
5. RATED VOLTAGE AND FREQUENCY	3Ø 220V 60HZ	
6. MOTOR TYPE	SQUIRREL CAGE ROTOR YPE	
7. RATING	30 MIN	
8. LOCATION	IN-DOOR , OUT-DOOR	
9. INSULATION CLASS	F	
10. DESIGN TEMPERATURE RISE (BY RESISTANCE)	80°C	
11. FULL LOAD SPEED	1660 RPM	
12. FULL LOAD CURRENT	5.7 A	
13. STARTING CURRENT AT RATED VOLTAGE	16.2 A	
14. MINIMUM STATING VOLTAGE	198 V	
15. EFFICIENCY AT 100% RAGED LOAD	70.2%	
16. POWER FACTOR AT 100% RATED LOAD	56.0%	
17. STARTING TORQUE	269%	
18. TYPE OF ENCLOSURE	전폐형	
19. TYPE OF BEARING	PL : 6005DD OPL : 6206ZZ	
20. MOUNTING	VERTICAL	
21. MAXIMUM AMBIENT TEMPERATURE	40°C	
22. BEARING LUBRICATION	GREASE	
23. STARTING METHOD	FULL VOLTAGE	

TECHNICAL DATA

1. SERVICE	HOISTING
2. MANUFACTURE	DAESAN INOTEC INC.
3. MOTOR MODEL NO.	EDL - 500KG - 380
4. RATED POWER	0.75 KW x 4 P
5. RATED VOLTAGE AND FREQUENCY	3Ø 380V 60HZ
6. MOTOR TYPE	SQUIRREL CAGE ROTOR YPE
7. RATING	30 MIN
8. LOCATION	IN-DOOR , OUT-DOOR
9. INSULATION CLASS	F
10. DESIGN TEMPERATURE RISE (BY RESISTANCE)	80°C
11. FULL LOAD SPEED	1660 RPM
12. FULL LOAD CURRENT	3.0 A
13. STARTING CURRENT AT RATED VOLTAGE	8.57 A
14. MINIMUM STATING VOLTAGE	342 V
15. EFFICIENCY AT 100% RAGED LOAD	70.2%
16. POWER FACTOR AT 100% RATED LOAD	59.0%
17. STARTING TORQUE	265%
18. TYPE OF ENCLOSURE	전폐형
19. TYPE OF BEARING	PL : 6005DD OPL : 6206ZZ
20. MOUNTING	VERTICAL
21. MAXIMUM AMBIENT TEMPERATURE	40°C
22. BEARING LUBRICATION	GREASE
23. STARTING METHOD	FULL VOLTAGE

SPECIFICATION FOR ELECTRIC MOTORS	INTERNAL IDENTIFICATION NO.	PAGE : REV :
TECHNICAL DATA		
1. SERVICE	HOISTING	
2. MANUFACTURE	DAESAN INOTEC INC.	
3. MOTOR MODEL NO.	EDL - 500KG - 440	
4. RATED POWER	0.75 KW x 4 P	
5. RATED VOLTAGE AND FREQUENCY	3Ø 440V 60HZ	
6. MOTOR TYPE	SQUIRREL CAGE ROTOR YPE	
7. RATING	30 MIN	
8. LOCATION	IN-DOOR , OUT-DOOR	
9. INSULATION CLASS	F	
10. DESIGN TEMPERATURE RISE (BY RESISTANCE)	80°C	
11. FULL LOAD SPEED	1660 RPM	
12. FULL LOAD CURRENT	2.7 A	
13. STARTING CURRENT AT RATED VOLTAGE	7.7 A	
14. MINIMUM STATING VOLTAGE	396 V	
15. EFFICIENCY AT 100% RAGED LOAD	70.2%	
16. POWER FACTOR AT 100% RATED LOAD	59.0%	
17. STARTING TORQUE	265%	
18. TYPE OF ENCLOSURE	전폐형	
19. TYPE OF BEARING	PL : 6005DD OPL : 6206ZZ	
20. MOUNTING	VERTICAL	
21. MAXIMUM AMBIENT TEMPERATURE	40°C	
22. BEARING LUBRICATION	GREASE	
23. STARTING METHOD	FULL VOLTAGE	

SPECIFICATION FOR ELECTRIC MOTORS	INTERNAL IDENTIFICATION NO.	PAGE : REV :
TECHNICAL DATA		
1. SERVICE	HOISTING	
2. MANUFACTURE	DAESAN INOTEC INC.	
3. MOTOR MODEL NO.	EDL - 500KG - 460	
4. RATED POWER	0.75 KW x 4 P	
5. RATED VOLTAGE AND FREQUENCY	3Ø 460V 60HZ	
6. MOTOR TYPE	SQUIRREL CAGE ROTOR YPE	
7. RATING	30 MIN	
8. LOCATION	IN-DOOR , OUT-DOOR	
9. INSULATION CLASS	F	
10. DESIGN TEMPERATURE RISE (BY RESISTANCE)	80°C	
11. FULL LOAD SPEED	1660 RPM	
12. FULL LOAD CURRENT	2.5 A	
13. STARTING CURRENT AT RATED VOLTAGE	7.13 A	
14. MINIMUM STATING VOLTAGE	414 V	
15. EFFICIENCY AT 100% RAGED LOAD	70.2%	
16. POWER FACTOR AT 100% RATED LOAD	59.0%	
17. STARTING TORQUE	265%	
18. TYPE OF ENCLOSURE	전폐형	
19. TYPE OF BEARING	PL : 6005DD OPL : 6206ZZ	
20. MOUNTING	VERTICAL	
21. MAXIMUM AMBIENT TEMPERATURE	40°C	
22. BEARING LUBRICATION	GREASE	
23. STARTING METHOD	FULL VOLTAGE	

TECHNICAL DATA

1. SERVICE	HOISTING
2. MANUFACTURE	DAESAN INOTEC INC.
3. MOTOR MODEL NO.	EDL - 500KG - 480
4. RATED POWER	0.75 KW x 4 P
5. RATED VOLTAGE AND FREQUENCY	3Ø 480V 60HZ
6. MOTOR TYPE	SQUIRREL CAGE ROTOR YPE
7. RATING	30 MIN
8. LOCATION	IN-DOOR , OUT-DOOR
9. INSULATION CLASS	F
10. DESIGN TEMPERATURE RISE (BY RESISTANCE)	80°C
11. FULL LOAD SPEED	1660 RPM
12. FULL LOAD CURRENT	2.3 A
13. STARTING CURRENT AT RATED VOLTAGE	6.56 A
14. MINIMUM STATING VOLTAGE	432 V
15. EFFICIENCY AT 100% RAGED LOAD	70.2%
16. POWER FACTOR AT 100% RATED LOAD	59.0%
17. STARTING TORQUE	265%
18. TYPE OF ENCLOSURE	전폐형
19. TYPE OF BEARING	PL : 6005DD OPL : 6206ZZ
20. MOUNTING	VERTICAL
21. MAXIMUM AMBIENT TEMPERATURE	40°C
22. BEARING LUBRICATION	GREASE
23. STARTING METHOD	FULL VOLTAGE