

NO	DESCRIPTION	MAT'L	Q'TY	WT(kg)	REMARKS

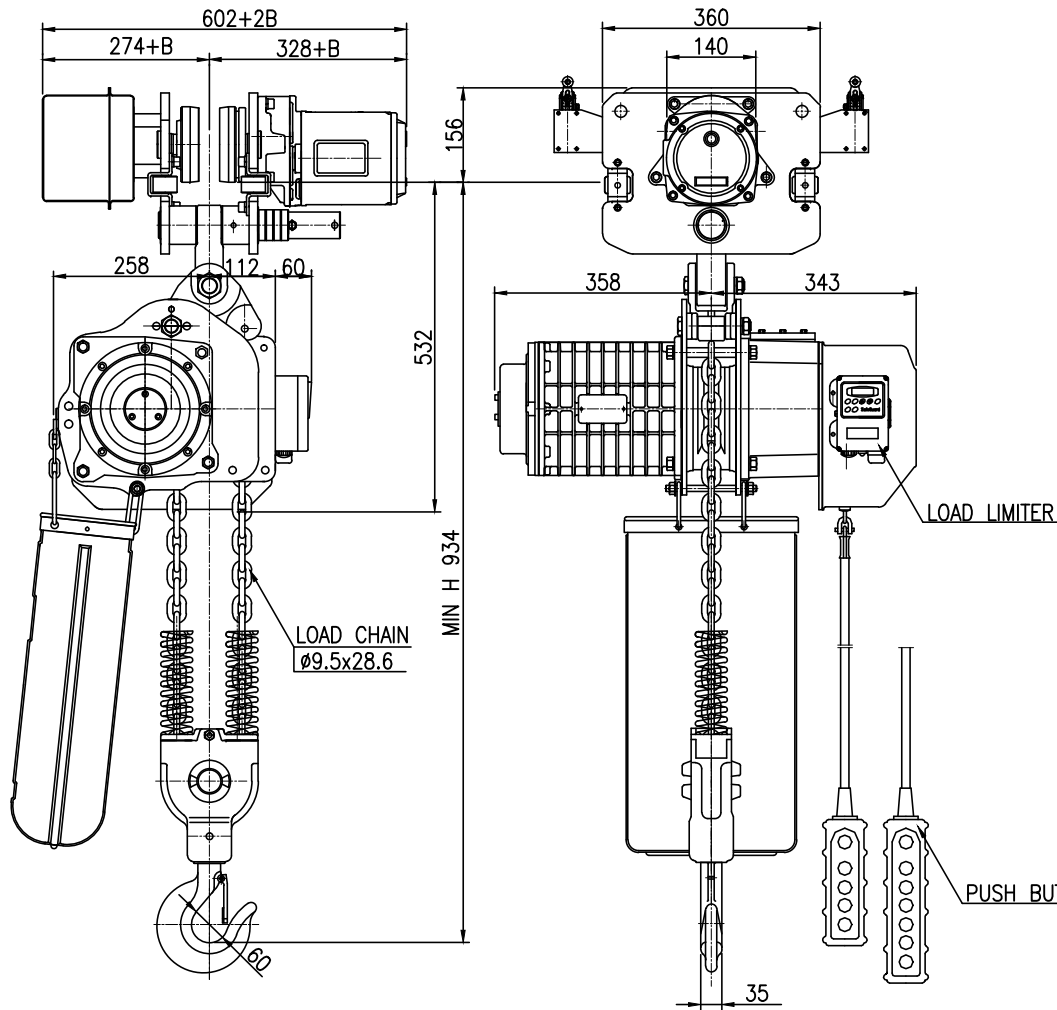

SPECIFICATION		
HOISTING LOAD	3	TON
TESTING LOAD	3.75	TON
LIFTING HEIGHT	5	M
HOISTING	SPEED	1.5-4.6 M/MIN
	MOTOR	3.5 KW x 4P x 1 SET
TRAVERSING	SPEED	5.2-15.2 M/MIN
	MOTOR	0.75 KW x 6P x 1 SET
POWER SUPPLY	AC 220,380,440.x3ø x 60 Hz	
OPERATING METHOD	P.B type ON . FL	
WEIGHT	225 KG	
I-BEAM SIZE	100-150 MM	

NOTE

- * B 는 BEAM 변동값임
- * ROLLER DIA : Ø125
- * LIMIT SWITCH : OPTION
- * 본 도면은 1-BEAM 100MM 기준임.

TITLE				EDSM-3W CHAIN HOIST		PROJECTION	
WORK NO		WORK NAME					
		SCALE		Q'TY			
		1/1		1			
DRAWN	CHECKED	REVIEWED	APPROVED	DRAWING NO			
H.J		LEE	Y. K	EDSM03W01			
2020.09.14		2020.09.14	2020.09.14				

도면에 지시되지 않은 일반공차						
가공별	치수	3-6	6-30	30-120	120-315	315-1000
선	삭					
구멍간	거리	±0.1	±0.2	±0.3	±0.5	±0.8

REV.NO	DATE	REVISION DESCRIPTION	DRAWN	CHECKED	APPROVED

DAESAN INoTEC INC