

NO	DESCRIPTION	MAT'L	Q'TY	WT(kg)	REMARKS

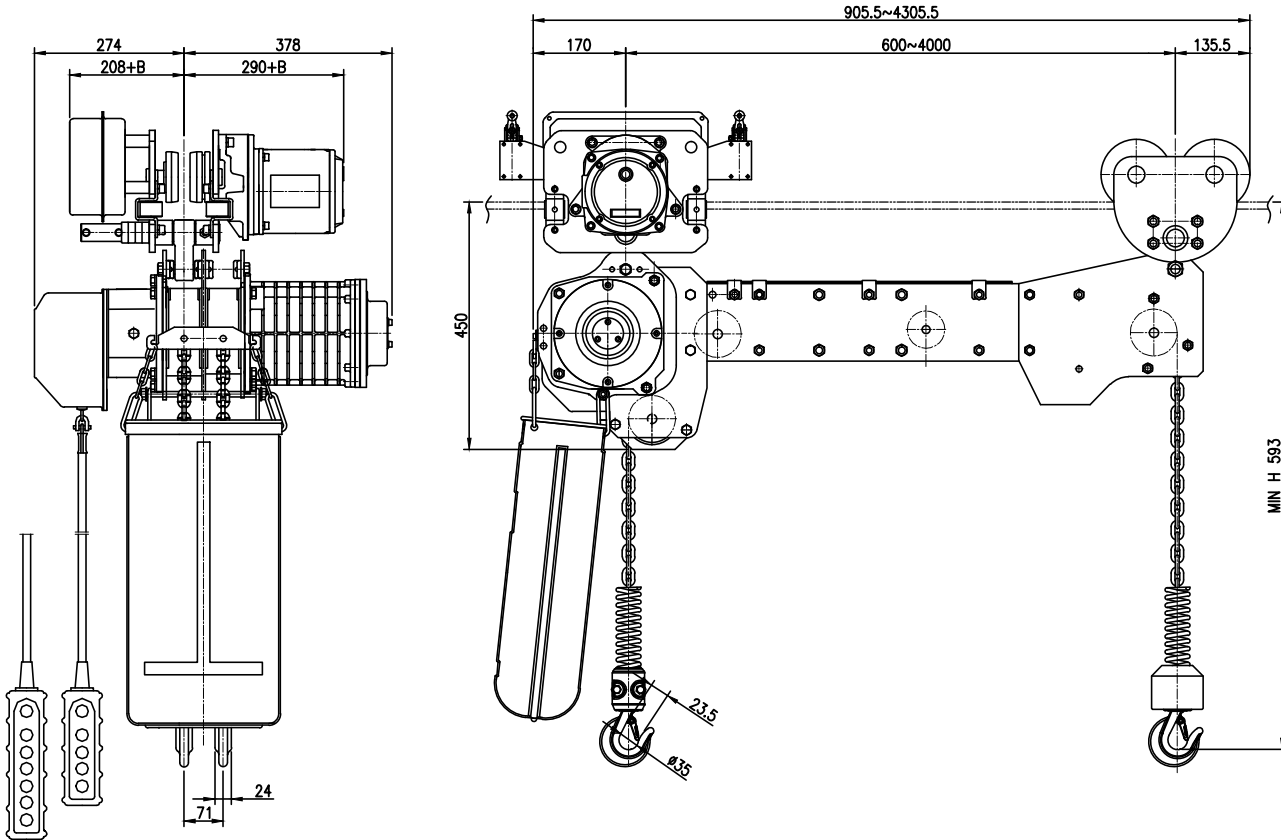

SPECIFICATION		
HOISTING LOAD	1	TON
TESTING LOAD	1.25	TON
LIFTING HEIGHT	4	M
HOISTING	SPEED	6.8/8.2 M/MIN
	MOTOR	1.8 KW x 4P x 1 SET
TRAVERSING	SPEED	15/21 M/MIN
	MOTOR	0.4 KW x 6/4P x 1 SET
POWER SUPPLY	AC 220,380,440,480 x 3φ x 50/60 Hz	
OPERATING METHOD	P.B type ON . FL	
I-BEAM SIZE	75-125	

NOTE

- * B는 BEAM 변동값임
- * ROLLER DIA : Ø95
- * LIMIT SWITCH : OPTION
- * 본 도면은 1-BEAM 75MM 기준임.

TITLE DSDHM-1S CHAIN HOIST				PROJECTION	
WORK NO		WORK NAME			
				SCALE	Q'TY
				1/1	1
DRAWN	CHECKED	REVIEWED	APPROVED	DRAWING NO	
H.J	-	LEE	Y.K	DSDHM010S1	
2020.09.15	-	2020.09.15	2020.09.15		

도면에 지시되지 않은 일반공차						
가공별	치수	3-6	6-30	30-120	120-315	315-1000
선	삭	±0.1	±0.2	±0.3	±0.5	±0.8
구멍간	거리	±0.1	±0.2	±0.3	±0.5	±0.8

REV.NO	DATE	REVISION DESCRIPTION	DRAWN	CHECKED	APPROVED

DAESAN INoTEC INC