

NO	DESCRIPTION	MAT'L	Q'TY	WT(kg)	REMARKS

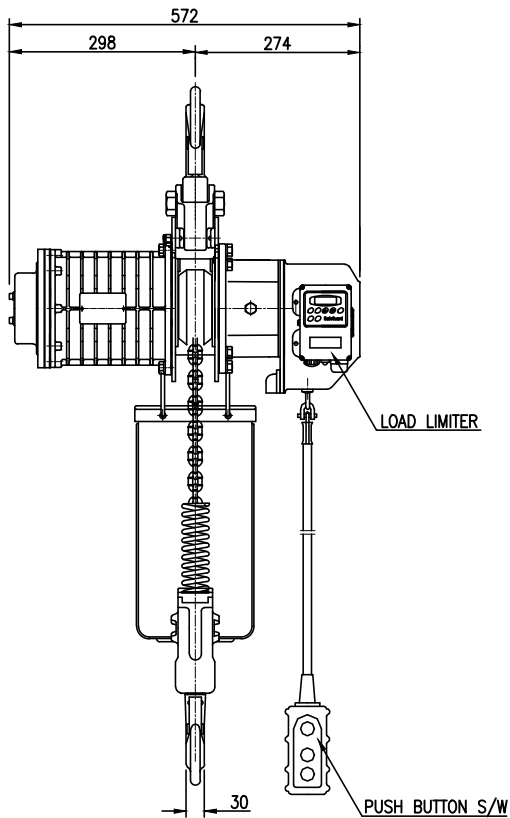
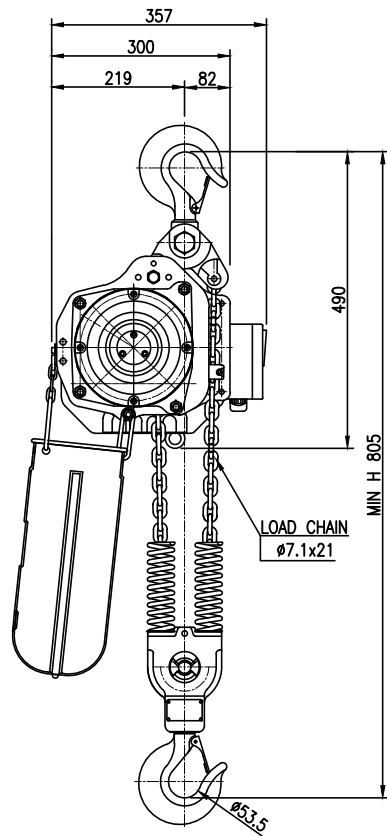

SPECIFICATION			
HOISTING LOAD	2	TON	
TESTING LOAD	2.5	TON	
LIFTING HEIGHT	4	M	
HOISTING	SPEED	50/60Hz	3.4/4.1 M/MIN
	MOTOR	1.8/1.2 KW x 4/6P x 1 SET	
POWER SUPPLY	AC220, 380, 440 x 3ø x 50/60 Hz		
OPERATING METHOD	P.B type ON . FL		
WEIGHT	85 KG		

TITLE DSA-2W CHAIN HOIST				PROJECTION	
WORK NO		WORK NAME			
				SCALE	Q'TY
				1/1	1
DRAWN	CHECKED	REVIEWED	APPROVED	DRAWING NO	
H.J		LEE	Y. K	DSA02W001	
2020.09.14		2020.09.14	2020.09.14		
<b>DAESAN INoTEC INC</b>					

도면에 지시되지 않은 일반공차						
가공별	치수	3-6	6-30	30-120	120-315	315-1000
선	삭					
구멍간	거리	±0.1	±0.2	±0.3	±0.5	±0.8

REV.NO	DATE	REVISION DESCRIPTION	DRAWN	CHECKED	APPROVED