

NO	DESCRIPTION	MAT'L	Q'TY	WT(kg)	REMARKS

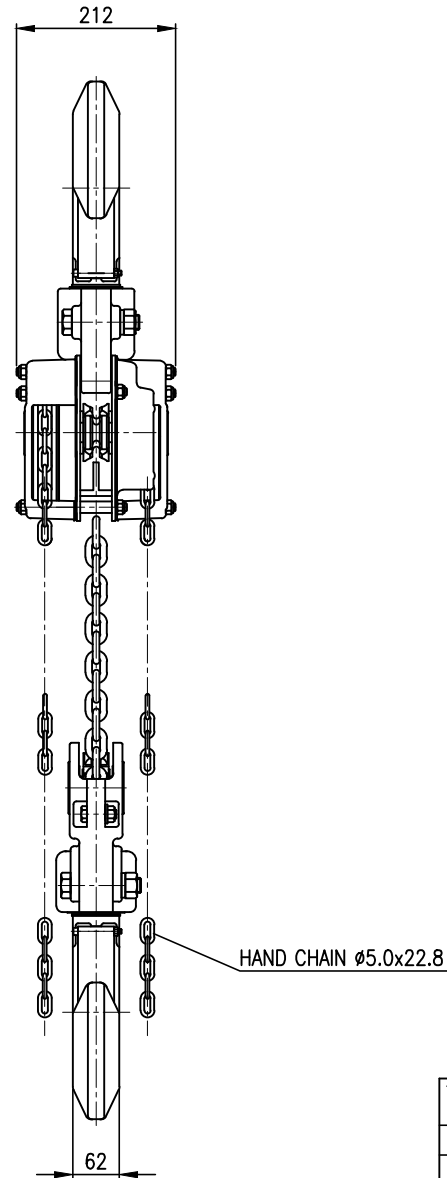
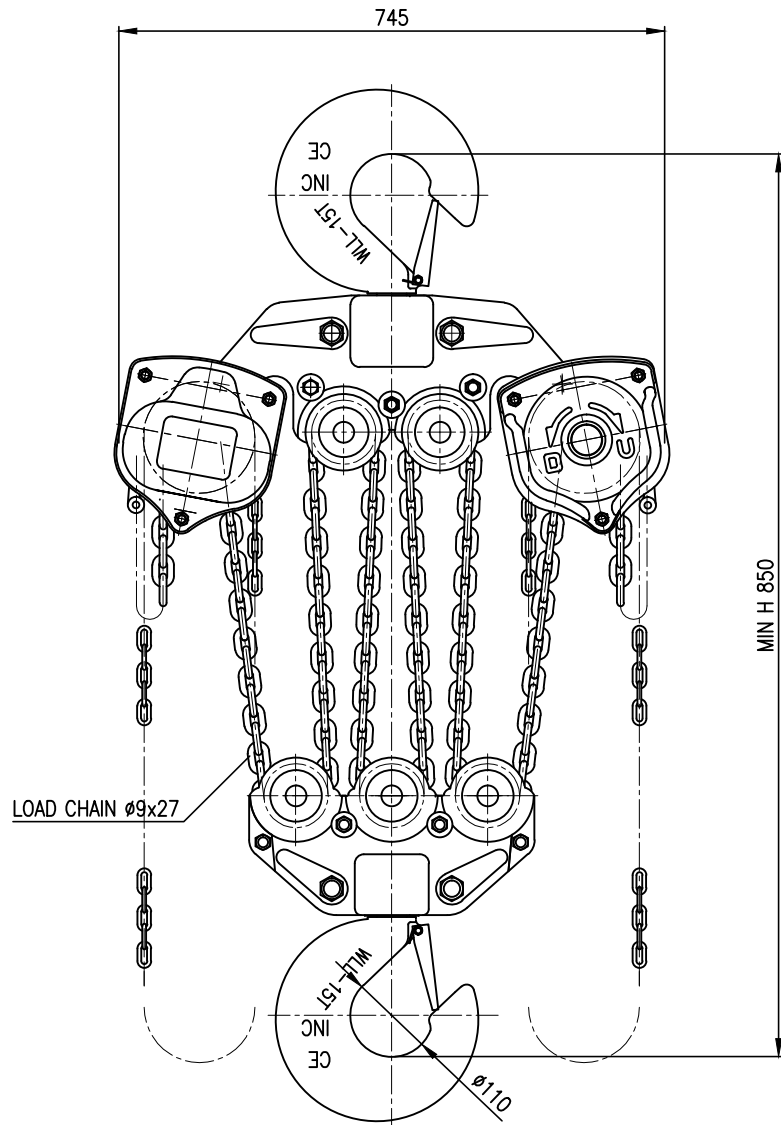

SPECIFICATION	
HOISTING LOAD	15 TON
TESTING LOAD	18.75 TON
LIFTING HEIGHT	3.5 M
HOISTING	MANUAL
WEIGHT	150 kg
LOAD CHAIN	ø9x27
HAND CHAIN	ø5x22.8

TITLE DSN-15TON CHAIN BLOCK				PROJECTION	
WORK NO		WORK NAME			
				SCALE	Q'TY
				1/4	1
DRAWN	CHECKED	REVIEWED	APPROVED	DRAWING NO	
YOO.M.R	-	LEE. H.J	Y. K	DSN15001	
2012.12.11	-	2012.12.11	2012.12.11		

REV.NO	DATE	REVISION DESCRIPTION	DRAWN	CHECKED	APPROVED

**DAESAN INoTEC INC**