

NO	DESCRIPTION	SIZE	Q'TY	REMARKS									
001	PLAIN ROLLER		4		017	HAND WHEEL		2		031	SNAP RING	S-45	8
002	BALL BEARING	6309ZZ	16		018	PINION GEAR		2		032	PINION NUT	M24	2
004	SNAP RING	R-100	8		019	PLAIN WASHER	M24	2		033	COTTER PIN	ø6x83	2
A05	PLAIN SIDE PLATE ASS'Y		2		020	CONNECTION PLATE		2		034	BUSHING		4
006	BRACKET		4		021	CONNECTION SHAFT		1		035	FIX PIN		8
007	STAY BOLT		2		022	KEY PLATE A		4		036	PACE PLATE		8
008	CONNECTOR		1		023	KEY PLATE B		2		037	PLAIN WASHER	M48	16
A09	GEAR SIDE PLATE ASS'Y		2		024	HEX BOLT S/W	M20x70	8		038	HEX NUT	M48	16
010	COLLAR		2		025	HEX NUT S/W	M24	4		040	BUSHING		2
011	CONNECTION COLLAR		2		026	HEX BOLT S/W	M20x45	8		041	PLAIN WASHER		8
012	CONNECTION PLATE		2		027	CHAIN BOX		2		042	ADJUSTING COLLAR A		4
013	GEAR ROLLER		4		028	HAND CHAIN		2		043	ADJUSTING COLLAR B		4
014	EYE NUT	M12	2		029	HEX BOLT S/W	M20x45	4		044	CLIP		2
015	G/T SHAFT		2		030	HEX BOLT S/W	M20x55	4		045	NAME PLATE		2

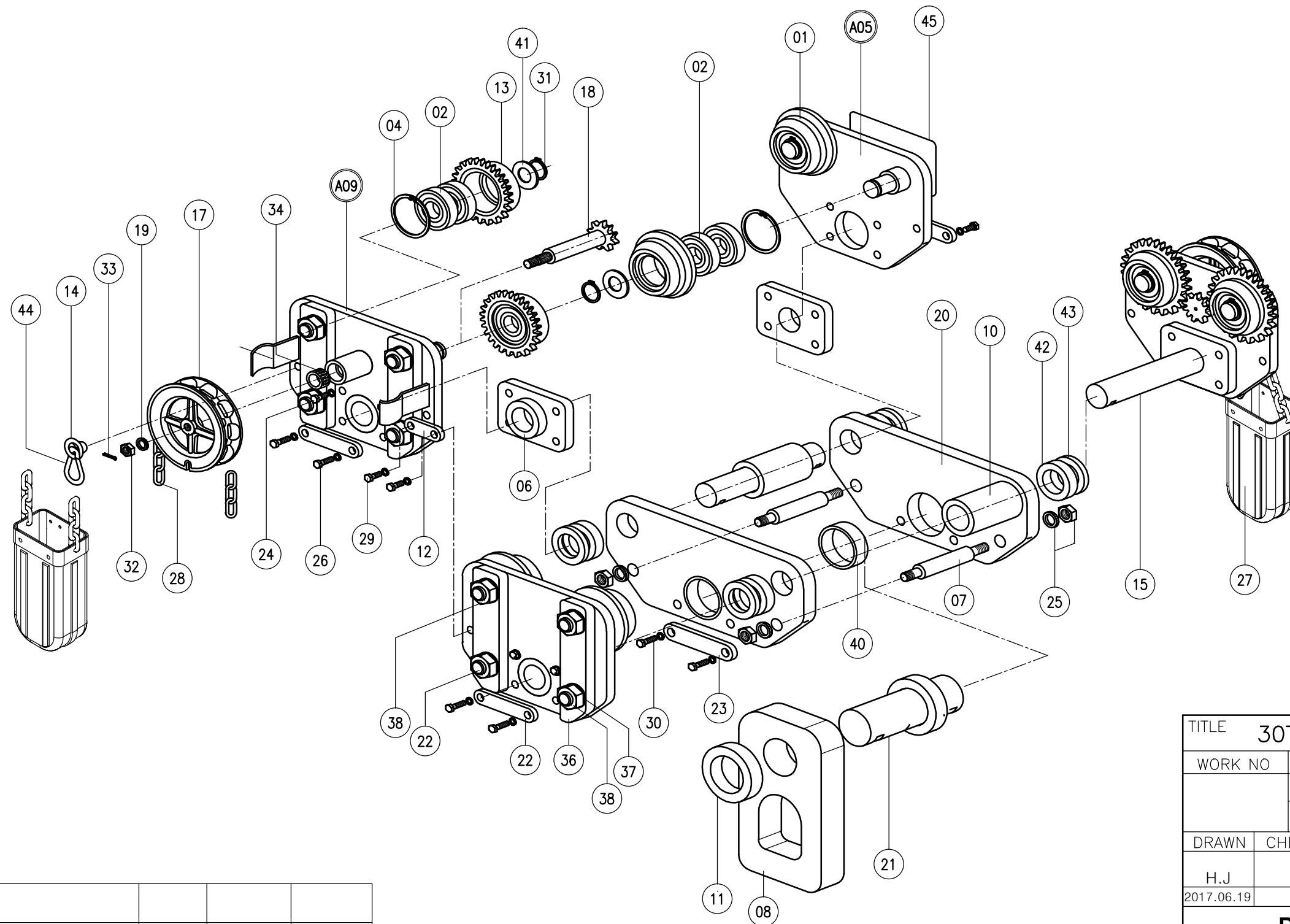

REV.NO	DATE	REVISION DESCRIPTION	DRAWN	CHECKED	APPROVED

TITLE				30TON GEAR TROLLEY		PROJECTION	
WORK NO		WORK NAME					
		SCALE		Q'TY		1/5	
DRAWN	CHECKED	REVIEWED	APPROVED	DRAWING NO			
H.J	-	LEE	Y. K	DSG300WE01			
2017.06.19	-	2017.06.19	2017.06.19				
<b>DAESAN INoTEC INC</b>							